



GENERAL TESTING SUMMARY



NATIONAL BUILDING CODE FIRE TESTING



1 Hour of Fire Exposure with no effect to the system and wall assembly.



CYCLIC PRESSURE (WINDSTORM SETTINGS)

Passed over 3,500 pressure cycles equivalent wind load of 165 mph.

GENERAL TESTING SUMMARY

TEST	SPECIFICATION	METHODOLOGY	RESULT
Salt Spray Resistance	ASTM B117-16	1000 Hours of exposure.	No deleterious effects.
Density of Sandwich Core	ASTM C271/C271M-16	12" X 12" X 0.6"	327 kg/m ³ (20.42 lbm/ft ³)
Flatwise Tensile Bond Strength	ASTM C297/C297M-16	Load was applied to the top and bottom layers of the composite panel.	1.52 MPa (220 psi)
Edgewise Compressive Strength	ASTM C364/C364M-16	Compressive load was applied at a rate of 0.02 in/min.	Ultimate Compressive Strength = 37.85 MPa (5490 psi)
Flatwise Tensile Bond Strength	ASTM C365	Load was applied to the top and bottom layers of the composite panel.	1.52 MPa (220 psi)

GENERAL TESTING SUMMARY

TEST	SPECIFICATION	METHODOLOGY	RESULT
Shear Strength by Beam Flexure	ASTM C393/C393M-16	Loaded in flexure with facing side in tension at a cross head speed of 0.025 in/min.	Maximum Core Shear Strength = 0.94 MPa (137 psi) Facing Bending Stress = 8.14 MPa (1180 psi)
Flexure Creep Evaluation	ASTM C480/C480M-16	Midspan loading setup was used with facing side in tension at a cross head speed of 0.025 in/min. until achieved.	Net Creep (in/day) Facing - 0.029.
Shear Stress and Shear Modulus	ASTM C273/C273M-18	Compressive force applied until rupture.	Ultimate Core shear strength = 1.01 MPa (147 psi) Core shear Modulus = 10.9 MPa (1583 psi)
Laboratory Aging of Sandwich Construction	ASTM C481-99 (Reapproved 2016)	Procedure A, for six repetitions of following load cycle is applied: Immerse in water at 50 °C for 1h Spray with steam at 95 °C for 3h Store at -12 °C for 20h Heated at 100 °C for 3h Spray with steam at 95 °C for 3h Heat in dry air at 100 °C for 18h.	ASTM C273; C297; C364; C393 tests were reconducted after aging: the variation was +1.36 %, -5.90%; +2.55%; -7.95%. Note: Positive variation indicates no decrease in strength after aging.
Resistance to Rapid Freezing and Thawing	ASTM C666/C666M-15	200 cycles of rapid freeze and thaw (4 °C to - 18 °C).	No visible change to facing, aluminum, or adhesive.
Flexural Strength	ASTM C880/C880M-15	Tested a Composite panel with Mitrex panel.	22.83 MPa (3311.21 psi)
Tensile Properties of Adhesive Bond	ASTM C897-08 (2016)	The adhesive bond never failed.	No Failure
Screw Withdrawal Test	ASTM D1761	Testing Speed: 2.5 mm/min.	2124 N

GENERAL TESTING SUMMARY

TEST	SPECIFICATION	METHODOLOGY	RESULT
Damage Resistance Testing of Sandwich Constructions	ASTM D7766/D7766M-16	Load was applied at the specimen midpoint through a 0.5 in. diameter hemispherical steel indenter at a constant rate of 0.01 in/min until a drop-in load was observed.	No panel deformation.
Air Leakage Resistance	ASTM E283-04 (2012)	Air infiltration and exfiltration tests were performed using test pressure of 75 Pa (1.57 psf). The maximum air leakage rate was calculated and compared to the allowable air leakage.	Passed the test infiltration rate = 0.00 L/s.m ² (0 cfm/ft ²) & exfiltration rate = 0.01 L/s.m ² (0.002 cfm/ft ²) at 75 Pa test pressure.
Static Air Pressure	ASTM E330 / TAS 203	The test specimen was also tested to failure with both positive and negative loads. The specimen only showed a permanent deflection of 0.10 mm with a test load of + 5760 Pa (120 psf). The specimen failed at -5006 Pa, the rivets at the backside of the specimen failed.	All the panels tested met or exceeded requirements.
Uniform Static Deflection	ASTM E330-02	The test specimen was tested to ±3840 Pa (80.2 psf) to examine the deflection of 2440 mm panel, the specimen showed a maximum net deflection of 4.14 mm under positive test pressure and 4.93 mm under negative load.	No failure or permanent damage.
Fluorescent Ultraviolet Radiation Exposure	ASTM G154 -16	2000 hours of UV exposure.	No visible change to Glass, aluminum, or adhesive.

GENERAL TESTING SUMMARY

TEST	SPECIFICATION	METHODOLOGY	RESULT
Large Missile Impact Test	ASTM E1996 / TAS 201	Standard Specification for Performance of Exterior Windows, Curtain Walls, Doors, and Impact Protective Systems Impacted by Windborne Debris in Hurricanes.	Passed the test. A weighted 2×4 was fired at the Mitrex panel at 50 fps.
Thermal Resistance	ASTM 1363-11	Thermal Performance of Building Materials and Envelope Assemblies by Means of a Hot Box Apparatus.	0.20 m ² oC/W (1.12 hr-ft ² -oF/BTU)
Linear Thermal Expansion	ISO 10545-8	Tested from room temperature to 100°C.	11.28 × 10 ⁻⁶ per °C
Cyclic Pressure Loading	ASTM E1886 / TAS 203	Standard Test Method for Performance of Exterior Windows, Curtain Walls, Doors, and Impact Protective Systems Impacted by Missile(s) and Exposed to Cyclic Pressure Differentials.	Passed the test. Over 3,500 positive and negative pressure cycles were applied at ± 2880 Pa (60 psf), equivalent wind load of 165 mph.
Water Penetration Resistance	ASTM E331-00(2016)	During the 15-minute test period, using a pressure differential of 720 Pa (15.0 psf), there was no water leakage observed.	No water leakage.

FIRE SAFETY

Tunnel Test	ASTM E84	Sample passed the test with Flame Spread Index = 0; smoke developed index = 0.
Non-Combustibility in Building Materials	ASTM E136	Mitrex sample passed the test requirements. There was no visible smoke or flame. The sample did not have a maximum temperature rise of more than 96.8°C on the indicating thermocouple. The samples did not loose more than 20% of their original mass.
Multi-Story Fire Test	NFPA 285	Passed.
Fire Endurance Tests of Building Construction and Materials	ASTM E119	1 hr Fire Exposure - The Mitrex Material did not affect the fire rated wall assembly.
Standard Method Fire Test of Exterior Wall Assemblies	S134	Passed.
Fire Classification of Construction Products and Building Elements	EN13501	Rating: A2-s1,d0

QUALITY TEST (IEC/UL 61215)

TEST	DESCRIPTION
MQT 01 Visual Inspection	<p>To detect any visual defects in module:</p> <ul style="list-style-type: none"> • Broken, cracked, or torn external surfaces. • Bent or misaligned external surfaces, including superstrates, substrates, frames and junction boxes to the extent that the operation of the PV module would be impaired. • Bubbles or delaminations forming a continuous path between electric circuit and the edge of the module. • If the mechanical integrity depends on lamination or other means of adhesion, the sum of the area of all bubbles shall not exceed 1% of the total module area. • Evidence of any molten or burned encapsulant, backsheet, front sheet, diode or active PV component. • Loss of mechanical integrity to the extent that the installation and operation of the module would be impaired.

QUALITY TEST (IEC/UL 61215)

TEST	DESCRIPTION
	<ul style="list-style-type: none"> · Cracked/broken cells which can remove more than 10% of the cell's photovoltaic active area from the electrical circuit of the PV module. · Voids in, or visible corrosion of any of the layers of the active (live circuitry of the module extending over more than 10% of any cell. · Broken interconnections, joints or terminals. · Any short-circuited live parts or exposed live electrical parts. · Module markings (label) are no longer attached, or the information is unreadable.
MQT 02 Maximum Power Determination	Checking the functionality of module and maximum power by checking the I-V curve.
MQT 03 Insulation Test	HiPot test with voltage of 3000V for PV modules with voltage system of 1000V for 1 min. again another HiPot test for 2 min with 1000V (system voltage).
MQT 04 Measurement of Temperature Coefficients	Determining temperature coefficients of current, voltage and peak power from module measurement.
MQT 05 Measurement of Nominal Module Operating Temperature (NMOT)	Determining the solar module characteristics (Voc, Isc and Pmax) in 800 W/m ² , 20 degree and wind speed of 1m/s.
MQT 06 Performance at STC and NMOT	Checking the short circuit current (Isc) and open circuit voltage (Voc) and IV-curve and comparing with the rating with tolerances for both STC (1000 W/m ² , 25 degree and AM = 1.5) and NMOT (800 W/m ² , 20 degree and wind speed of 1 m/s) conditions.
MQT 07 Performance at Low Irradiance	Determining the current-voltage characteristics of module at 25 degree and low irradiance of 200 W/m ² and having IV curve result.
MQT 08 Outdoor Exposure Test	Installing the module outdoor with load around its maximum power for at least 60 kWh/m ² . No defect should be found.

QUALITY TEST (IEC/UL 61215)

TEST	DESCRIPTION
MQT 09 Hot-Spot Endurance Test	Determining ability of module against hot-spot effects like solder melting or deterioration caused by faulty cells, mismatched cells, shadowing, or soiling. Using I-V curve tracer and IR scan to check the hot-spot by making shadow for every single cell.
MQT 10 UV Preconditioning Test	Install the module in a chamber with only UV light (between 280nm to 320 wavelength and 320 to 400nm) with maximum 250W/m ² and short-circuited module (or with load in maximum power) at the 60 degree temperature. Subject the module to total UV irradiance of at least 15kWh/m ² in the wavelength range between 280 to 400nm.
MQT 11 Thermal Cycling Test	Testing the module by changing the temperature repeatedly. Module to be installed in the chamber with temperature sensor attached to its middle. The temperature should change with no more than 100 degree per hour and stay at -40 and 85 for at least 10 min. during the test, module will carry the current when temperature increasing from -40 to 80 degree only. Below process will be taken 50 or 200 times.
MQT 12 Humidity Freeze Test	Testing the module in high temperature and humidity followed by sub-zero temperature. Temperature will arise to 85 degree at maximum 100 degree per hour and keep the module for 20h in humidity of RH 85%. Then cool down to zero and then -40 degree by the speed of max 100 and 200 degree per hour. And keep for 30 min. do this process for 10 cycles.

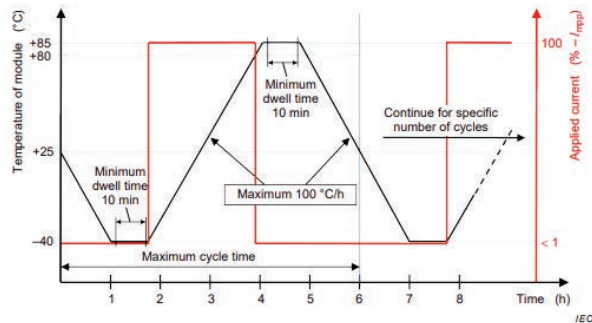

QUALITY TEST (IEC/UL 61215)

TEST

DESCRIPTION

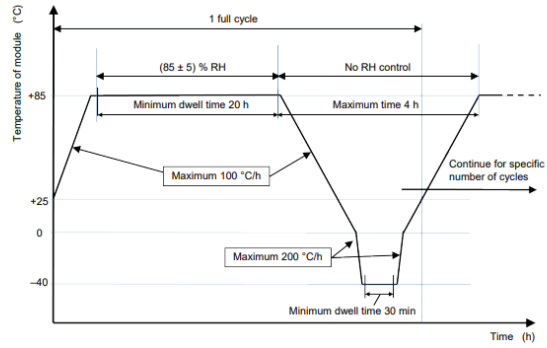

MQT 13
Damp Heat Test

Testing the ability of module for long term humid environment. The module will be at 85-degree temperature and 85 percent relative humidity and keep it there for 1000 h (or 200 h for another test) and no defect should be found.

MQT 14
Robustness of Terminations

Checking capability of withstanding of cables and termination attachments against stresses. Force of 40N for 10s in different direction will be applied to junction box to test its retention on module surface. Cable will be pulled 50 times for 1s in the direction or the axis and then torque test will be applied for 1 min.

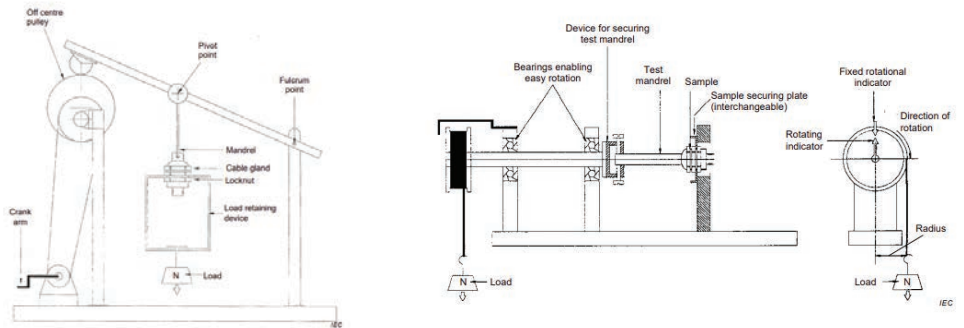

MQT 15
Wet Leakage Current test

Putting module in the tank of required solution to a depth sufficient to cover all surfaces (except junction box not designed for immersion). Then doing HiPot test for 2 min at system voltage (1000V).

MQT 16
Static Mechanical Load Test

Testing ability of withstanding with minimum static load. During the test electrical continuity of internal circuit should be monitored. Fixing the module on mounting base and applying 1 hour of 1.5 times of design load (per manufacturer) in front and back of the module respectively for three cycles.

QUALITY TEST (IEC/UL 61215)

TEST

DESCRIPTION

MQT 17
Hail Test

Testing the effect of hitting hail on the module surface (different location). Module will be installed on 90 degree tilt and room temperature. 11 hail ball at the diameter of minimum 25mm and speed of minimum 23 m/s will be fired through launcher. No major defect should be found.

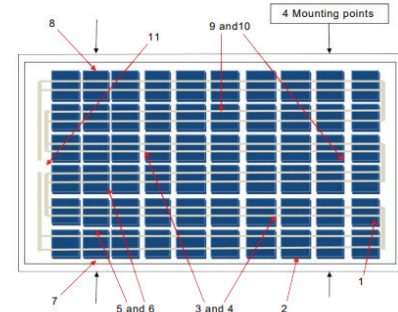
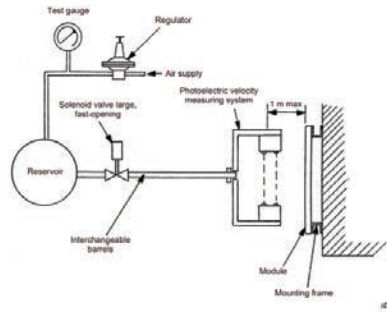

MQT 18
Bypass Diode
Testing

Checking the forward voltage of diode with short circuit current in 30, 50, 70 and 90 degree Celsius, then keep the current 100% and 125% of short circuit current for one hour and check the forward voltage at 75 degree. Then checking the functionality of diode after test. It could be done by successive IV-Curve tracer at maximum power by having shaded the strings to turn the diode ON or connecting the IV-Curve tracer in reverse polarity to turn the diode ON.

MQT 19
Stabilization

Checking the power of module to make sure it is stabilized electrically. The power testing on three consecutive should follow below relation:

$$(P_{\max} - P_{\min}) / P_{\text{average}} < x$$

Stabilization will be done in the beginning to check the label of each module and at the end of test to make sure degradation did not affect on the modules.

QUALITY TEST (IEC/UL 61215)

TEST	DESCRIPTION
	<p>IEC classified the tests in few categories just to have better view on all tests as follow:</p> <ul style="list-style-type: none"> • Environmental stress tests (MST 51, MST 52, MST 53, MST 54, MST 55, MST 56) • General inspection tests (MST 01, MST 02, MST 03, MST 04, MST 05, MST 06, MST 07) • Electrical shock hazard tests (MST 11, MST 12, MST 13, MST 14, MST 16, MST 17, MST 42) • Fire hazard tests (MST 21, MST 22, MST 23, MST 24, MST 25, MST 26) • Mechanical stress tests (MST 32, MST 33, MST 34, MST 35, MST 36, MST 37, MST 42)
MST 01 Visual Inspection	Checking any visual defect or change in the module; (marking, sharp edge, bubbles, crack, delamination, bent, mechanical integrity, ...)
MST 02 Performance at STC	Checking the short circuit current (Isc) and open circuit voltage (Voc) and comparing with the rating with tolerances (same as MQT 06)
MST 03 Maximum Power Determination	Checking the functionality of module and maximum power by checking the I-V curve (same as MQT 02)
MST 04 Insulation Thickness Test	Checking the thickness of insulation thin layers (backsheet) in three points as worst cases at solder connection, edge of frameless PV modules, laminator membrane indents. The measurement should be bigger than requirement (0.15mm+tolerance%)
MST 05 Durability of Marking	Checking durability and legibility of markings on the solar panels with medium pressure 15 second by hand and cloth soaked with water and again with petroleum spirits.
MST 06 Sharp Edge Test	Accessible part of solar modules should be smooth and free from sharp edges, burrs, ...
MST 07 Bypass Diode Functionality Test	Checking the functionality of diode after test. It could be done by successive IV-Curve tracer at maximum power by having shaded the strings to turn the diode ON or connecting the IV-Curve tracer in reverse polarity to turn the diode ON. (same as MQT 18.2)

SAFETY TEST (IEC/UL 61730)

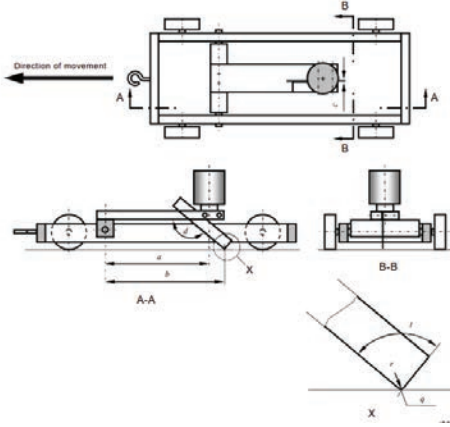
TEST	DESCRIPTION
MST 11 Accessibility Test	Checking the insulation resistance off all part of module that may be accessible to the live part by cylindrical test fixture at the pressure of 10N and at all time the resistance should be higher than 1MΩ.
MST 12 Cut susceptibility Test	Testing withstanding of polymeric material surface of module with specific fixture with force of 9N. 
MST 13 Continuity Test of Equipotential Bonding	Verifying continuous path between accessible conductive parts. Applying 2.5 times of maximum protective device current (for example 15A x 2.5) and checking the voltage for different conductive parts. Resistive should be less than 0.1Ω.
MST 14 Impulse Voltage Test	Testing capability of insulation of PV module against overvoltage (from atmosphere like impulse and switching of low-voltage equipment). Module will be covered by conductive metal foil and surge voltage will be applied to module. Dielectric should not breakdown.
MST 16 Insulation Test	HiPot test with voltage of 6000V for PV modules with voltage system of 1000V. (same as MQT 03)
MST 17 Wet Leakage Current Test	Putting module in the tank of required solution to a depth sufficient to cover all surfaces (except junction box not designed for immersion). Then doing HiPot test for 2 min at system voltage (1000V). (same as MQT 15)
MST 21 Temperature Test	Putting module on black painted wooden platform and checking the temperature of different location of module (normalised by changing of ambient temperature) in maximum power and no wind. Normalized temperature should not reach TI/RTE/RTI. (for example 90 degree)

SAFETY TEST (IEC/UL 61730)

TEST	DESCRIPTION
MST 22 Hot-Spot Endurance	Determining ability of module against hot-spot effects like solder melting or deterioration caused by faulty cells, mismatched cells, shadowing, or soiling. Using I-V curve tracer and IR scan to check the hot-spot by making shadow for every single cell. (same as MQT 09)
MST 23 Fire Test	Fundamental requirements for fire safety are not internationally harmonised. Fire resistance requirements for a PV module intended for building applications are defined in local or national building codes.
MST 24 Ignitability Test	Testing ignitability of vertical mounted PV by direct small flame under zero irradiance by external heat source. All exposed combustible material will be tested (but junction boxes, cables, and connectors). Flame will be applied at least 40mm above the bottom edge of the sample for 15s.
MST 25 Bypass Diode thermal test	Checking the forward voltage of diode with short circuit current in 30, 50, 70 and 90 degree Celsius, then keep the current 100% and 125% of short circuit current for one hour and check the forward voltage at 75 degree. Then following MST 07 for checking the functionality of diode. (same as MQT 18)
MST 26 Reverse Current Overload Test	Checking the risk of fire or ignition in reverse current situation. Putting module facedown to the mounting and covered by white tissue paper. Back of module should be covered by single layer of white tissue paper. With no irradiance, 1.35 times of maximum fuse size should apply to the module in reverse direction. No glass break or flaming should happen.
MST 32 Module Breakage Test	The weight of bag is around 45.5kg. Module should be mount on the frame and bag should be max 13mm far from surface and max 50mm from the centre of module. Drop height should be 300mm, and release after stabilizing.

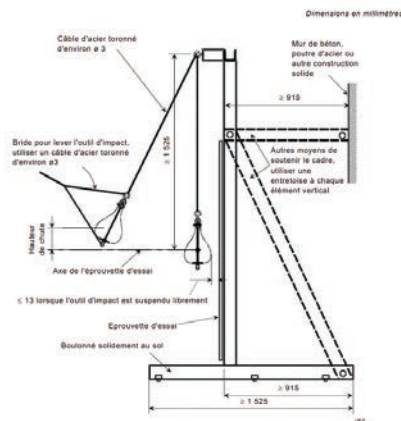

SAFETY TEST (IEC/UL 61730)

TEST	DESCRIPTION
MST 33 Screw Connections Test	Testing screws and nuts in completely loosening and tightening (to the specified torque) for five times.
MST 34 Static Mechanical Load	Testing ability of withstanding with minimum static load. During the test electrical continuity of internal circuit should be monitored. Fixing the module on mounting base and applying 1 hour of 1.5 times of design load (per manufacturer) in front and back of the module respectively for three cycles. (same as MQT 16)
MST 35 Peel Test	This test is only for cemented joint. Not sure this test is applicable to our product (based on the tables 3 and 4 of IEC 61730-1). But include tensile test in some adhesion part between encapsulant and back-sheet. Module should be unframed.
MST 36 Lap Shear Strength Test	Same as MST 35 but for glass/glass module tensile test.
MST 37 Material Creep Test	Checking the adhesive between different part of module (frontsheet and backsheet, FS or BS to mounting system, JB to BS) will be done in this test. Putting the module in chamber on mounting base and increasing temperature to 105 degree for 200 hours.
MST 42 Robustness of Termination Test	Checking capability of withstanding of cables and termination attachments against stresses. Force of 40N for 10s in different direction will be applied to junction box to test its retention on module surface. Cable will be pulled 50 times for 1s in the direction or the axis and then torque test will be applied for 1 min. (same as MQT 14)

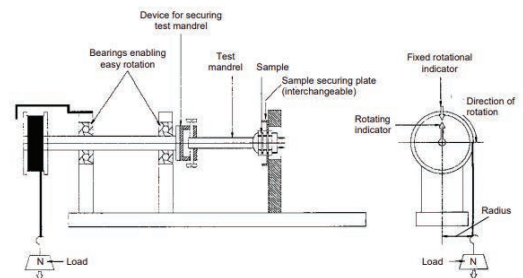
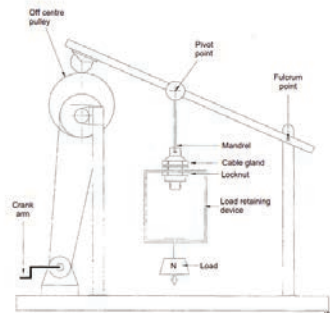

SAFETY TEST (IEC/UL 61730)

TEST

DESCRIPTION

MST 51
Thermal
Cycling Test

Testing the module by changing the temperature repeatedly. Module to be installed in the chamber with temperature sensor attached to its middle. The temperature should change with no more than 100 degree per hour and stay at -40 and 85 for at least 10 min. during the test, module will carry the current when temperature increasing from -40 to 80 degree only. Below process will be taken 50 or 200 times. (same as MQT 11)

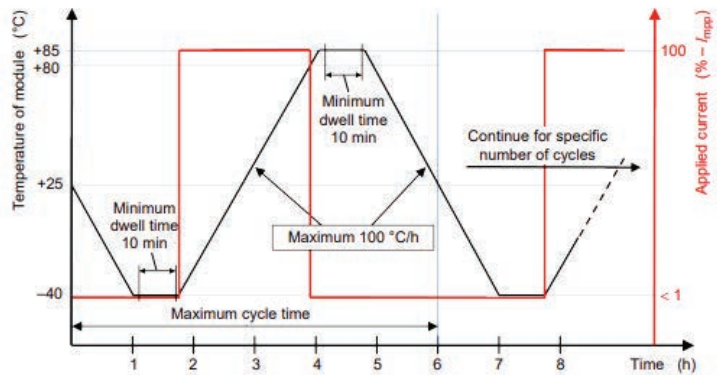

MST 52
Humidity
Freeze Test

Testing the module in high temperature and humidity followed by sub-zero temperature. Temperature will arise to 85 degree at maximum 100 degree per hour and keep the module for 20h in humidity of RH 85%. Then cool down to zero and then -40 degree by the speed of max 100 and 200 degree per hour. And keep for 30 min. do this process for 10 cycles. (same as MQT 12)

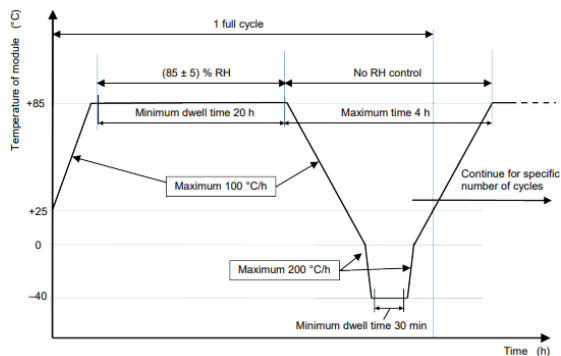

MST 53
Damp Heat Test

Testing the ability of module for long term humid environment. The module will be at 85-degree temperature and 85 percent relative humidity and keep it there for 1000 h (or 200 h for another test) and no defect should be found. (same as MQT 13)

SAFETY TEST (IEC/UL 61730)

TEST	DESCRIPTION
MST 54 UV Test	Install the module in a chamber with only UV light (between 280nm to 320 wavelength and 320 to 400nm) with maximum 250W/m ² and shortcircuited module (or with load in maximum power) at the 60 degree temperature. Subject the module to total UV irradiance of at least 15kWh/m ² or 60kWh/m ² in the wavelength range between 280 to 400nm. (same as MQT 10 for 15kWh/m ²)
MST 55 Cold Conditioning	Install the module in a chamber with temperature sensor and keep it there for 48 h with -40 degree. No defect should be found.
MST 56 Dry Heat Conditioning	Install the module in a chamber with temperature sensor. Keep the module in a chamber with 105 degree and less than 50% relative humidity for 200 h. No defect should be found.



BUILDING-INTEGRATED SOLAR TECHNOLOGY

Learn More:

 mitrex.com

 info@mitrex.com

 +1 (855) 254 0214 (Toll Free)

Headquarters:

 41 Racine Rd., Toronto,
ON M9W 2Z4, Canada

 +1 (416) 497 7120

West USA Office:

 10880 Wilshire Blvd Suite 1101,
Los Angeles, CA 90024, USA

 +1 (323) 301 7978

East USA Office:

 1 Rockefeller Plaza Fl 11,
New York, NY 10020, USA

 +1 (646) 583 4486