



BUILDING-INTEGRATED SOLAR TECHNOLOGY

---

## SOLAR EQUIPMENT & SPACE REQUIREMENT

MITREX SOLAR FACADE -  
500kW INDUSTRIAL

## 1. INTRODUCTION

Photovoltaic systems offer a promising solution to combat global warming while providing sustainable energy for the future. In utility scales, solar farms are prevalent and interconnected with the grid. For enhanced efficiency and reduced loss, it is beneficial to have load and generation sources situated close to each other. Solar projects implemented in or on buildings are particularly advantageous as they harness most of the solar energy for immediate use within the building. This approach not only minimizes losses but also alleviates congestion in transmission and distribution lines.

## 2. FOR BUILDING OWNERS

A crucial concern for building owners is the electrical equipment required for solar projects. Beyond cost considerations, they worry about the space these equipment installations demand. This document addresses the necessary equipment for various PV project sizes and scenarios.

## 3. LOGISTICS CONSIDERATIONS

BIPV (Building Integrated Photovoltaics) and regular rooftop solar installations as BAPV (Building applied photovoltaics) differ in terms of installation locations, solar panel types, and mounting equipment. However, both BIPV and BAPV systems share similar components apart from the solar panels. In rooftop projects, a designated area on the flat or tilted roof is necessary. In contrast, BIPV panels replace specific building elements such as facades, windows, railings, and so on, eliminating the need for additional space.

Additional equipment, such as AC equipment, requires some space on the roof, wall, or inside the building (like electrical or mechanical room). The specific requirements for AC equipment depend on factors such as the system size, number of electricity phases (single phase or three phases), maximum DC voltages allowed in the building, and local distribution company (LDC) regulations. When inverters are placed inside the building, DC cables need to be carefully routed through conduits, necessitating penetration points in the structure. The number and size of conduits vary according to each scenario, as detailed in the accompanying table.

## 4. REQUIRED AC EQUIPMENT FOR DIFFERENT SCENARIOS

Mitrex Panels, both BIPV and BAPV, are suitable for a 1000V system voltage. However, certain buildings may be restricted to a maximum of 600V DC based on local codes. Electricity services typically operate at 240V single phase or 208V, 480V, and 600V three phases. The table below outlines the required AC equipment for all the aforementioned scenarios, considering different system sizes.

		600V DC MAX SYSTEM			
# OF PHASES	SINGLE PHASE	THREE PHASE			
VOLTAGE	240V	208V	480V	600V	
5kW	Inverter	Solaredge SE5000H-US	---	---	---
	Disconnect	240V 30A Disconnect	---	---	---
	Panelboard	---	---	---	---
	Transformer	---	---	---	---
	Conduit	1" Conduit	---	---	---
	SCADA	---	---	---	---
10kW	Inverter	Solaredge SE10000H-US	Solaredge SE10KUS	Fronius Symo 15.0-3	Solaredge SE10KUS
	Disconnect	240V 60A Disconnect	240V 60A Disconnect	600V 30A Disconnect x 2	600V 30A Disconnect x 3
	Panelboard	---	---	---	---
	Transformer	---	---	---	600V/208V 15kVA TX
	Conduit	1 1/4" Conduit	1 1/4" Conduit	1 1/2" Conduit	1 1/4" Conduit
	SCADA	---	---	---	---
20kW	Inverter	Solaredge SE10000H-US x 2	Solaredge SE10KUS x 2	Fronius Symo 20.0-3	Solaredge SE10KUS x 2
	Disconnect	240V 200A Disconnect	240V 100A Disconnect	600V 30A Disconnect x 2	600V 30A Disconnect x 2
	Panelboard	240V 200A Panel	240V 100A Panel	---	600V 100A Panel
	Transformer	---	---	---	600V/208V 30kVA TX
	Conduit	1 1/2" Conduit	2" Conduit	1 1/2" Conduit	2" Conduit
	SCADA	---	---	---	---
50kW	Inverter	---	Solaredge SE17.3KUS x 3	SMA Core1 33.3kW x 2	SMA Core1 33.3kW x 2
	Disconnect	---	240V 200A Disconnect	600V 60A Disconnect x 2	600V 60A Disconnect x 2
	Panelboard	---	240V 200A Panel	600V 100A Panel	600V 100A Panel
	Transformer	---	---	---	600V/480V 75kVA TX
	Conduit	---	2" Conduit	3" or 2 x 2" Conduit	3" or 2 x 2" Conduit
	SCADA	---	Depends on the Hydro	Depends on the Hydro	Depends on the Hydro
100kW	Inverter	---	Solaredge SE17.3KUS x 6	SMA Core1 33.3kW x 3	SMA Core1 33.3kW x 3
	Disconnect	---	240V 400A Disconnect	600V 200A Disconnect x 2	600V 200A Disconnect x 2
	Panelboard	---	240V 400A Panel	600V 200A Panel	600V 200A Panel
	Transformer	---	---	---	600V/480V 150kVA TX
	Conduit	---	3" or 2 x 2" Conduit	4" or 2 x 3" or 3 x 2" Conduit	4" or 2 x 3" or 3 x 2" Conduit
	SCADA	---	Depends on the Hydro	Depends on the Hydro	Depends on the Hydro
500kW	Inverter	---	---	SMA Core1 33.3kW x 15	SMA Core1 33.3kW x 15
	Disconnect	---	---	600V 600A Disconnect x 2	600V 600A Disconnect x 2
	Panelboard	---	---	600V 800A Panel	600V 800A Panel
	Transformer	---	---	---	600V/480V 500kVA TX
	Conduit	---	---	5 x 4" Conduit	5 x 4" Conduit
	SCADA	---	---	Depends on the Hydro	Depends on the Hydro

		1000V DC MAX SYSTEM			
# OF PHASES	SINGLE PHASE	THREE PHASE			
VOLTAGE	240V	208V	480V	600V	
5kW	Inverter	Fronius Primo 5.0-1	---	---	---
	Disconnect	240V 30A Disconnect	---	---	---
	Panelboard	---	---	---	---
	Transformer	---	---	---	---
	Conduit	1 1/4" Conduit	---	---	---
	SCADA	---	---	---	---
10kW	Inverter	Fronius Primo 10.0-1	Fronius Symo 10.0-3 (208V)	Fronius Symo 10.0-3	Fronius Symo 10.0-3
	Disconnect	240V 60A Disconnect	240V 60A Disconnect	600V 30A Disconnect x 2	600V 30A Disconnect x 3
	Panelboard	---	---	---	---
	Transformer	---	---	---	600V/480V 15kVA TX
	Conduit	1 1/2" Conduit	1 1/2" Conduit	1 1/2" Conduit	1 1/2" Conduit
	SCADA	---	---	---	---
20kW	Inverter	Fronius Primo 10.0-1 x 2	Fronius Symo 10.0-3 (208V) x 2	Fronius Symo 20.0-3	Fronius Symo 20.0-3
	Disconnect	240V 200A Disconnect	240V 100A Disconnect	600V 30A Disconnect x 2	600V 30A Disconnect x 3
	Panelboard	240V 200A Panel	240V 100A Panel	---	---
	Transformer	---	---	---	600V/480V 30kVA TX
	Conduit	2" Conduit	2" Conduit	1 1/2" Conduit	1 1/2" Conduit
	SCADA	---	---	---	---
50kW	Inverter	---	Fronius Symo 15.0-3 (208V) x 3	SMA Corel 50kW	SMA Corel 50kW
	Disconnect	---	240V 200A Disconnect	600V 60A Disconnect x 2	600V 60A Disconnect x 3
	Panelboard	---	240V 200A Panel	---	---
	Transformer	---	---	---	600V/480V 75kVA TX
	Conduit	---	3" or 2 x 2" Conduit	1 1/2" Conduit	1 1/2" Conduit
	SCADA	---	Depends on the Hydro	Depends on the Hydro	Depends on the Hydro
100kW	Inverter	---	Fronius Symo 15.0-3 (208V) x 7	Solaredge SE100KUS	Solaredge SE100KUS
	Disconnect	---	240V 400A Disconnect	600V 200A Disconnect x 2	600V 200A Disconnect x 3
	Panelboard	---	240V 400A Panel	---	---
	Transformer	---	---	---	600V/480V 150kVA TX
	Conduit	---	4" or 2 x 3" or 4 x 2" Conduit	2 1/2" or 2 x 1 1/2" PVC Conduit	2 1/2" or 2 x 1 1/2" PVC Conduit
	SCADA	---	Depends on the Hydro	Depends on the Hydro	Depends on the Hydro
500kW	Inverter	---	---	Solaredge SE100KUS x 5	Solaredge SE100KUS x 5
	Disconnect	---	---	600V 600A Disconnect x 2	600V 600A Disconnect x 2
	Panelboard	---	---	600V 800A Panel	600V 800A Panel
	Transformer	---	---	600V/480V 500kVA TX	600V/480V 500kVA TX
	Conduit	---	---	2 x 4" or 5 x 2 1/2" Conduit	2 x 4" or 5 x 2 1/2" Conduit
	SCADA	---	---	Depends on the Hydro	Depends on the Hydro

---

CASE STUDY

## 500KW SYSTEM ON MIDRISE INDUSTRIAL BUILDING

**BUILDING TYPE:**

Industrial building with 1920 panels of 320W (total 614.4 kW DC)

**SYSTEM SIZE:**

5 x 100kW Solaredge inverter SE100KUS

**SYSTEM LAYOUT:**

60 strings of 32 panels with two building penetration holes (Conduit size 4")

**PROJECT SOLAR EQUIPMENT:**

One AC Panelboard 800A 600V, One 500kVA transformer 480V/600V, two 600A 600V disconnect switches (One could be replaced with breaker inside the main building switchboard if available)



500kW SYSTEM WIRING LAYOUT: HOME RUN TO THE BUILDING BASEMENT

TOP VIEW

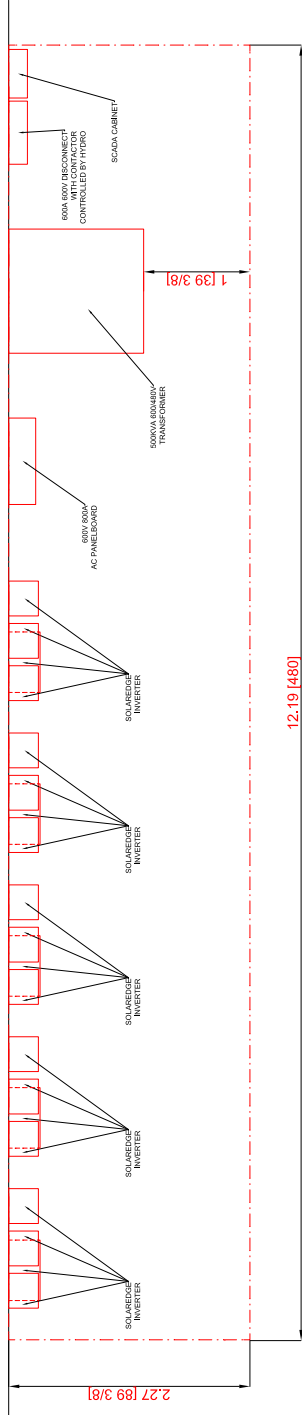

Note: Working area is 1m (39.37in) in front of solar equipments as per electrical code.

FRONT VIEW

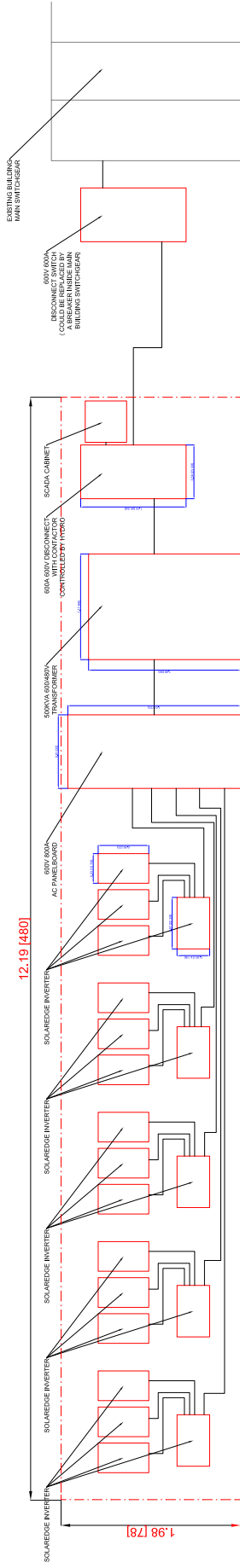

# Three Phase Inverter with Synergy Technology

For the 277/480V Grid for North America

SE80KUS / SE100KUS / SE110KUS / SE120KUS



## Powered by unique pre-commissioning process for rapid system installation

- Pre-commissioning feature for automated validation of system components and wiring during the site installation process and prior to grid connection
- Easy 2-person installation with lightweight, modular design (each inverter consists of 2 or 3 Synergy units and 1 Synergy Manager)
- Independent operation of each Synergy unit enables higher uptime and easy serviceability
- Built-in thermal sensors detect faulty wiring, ensuring enhanced protection and safety
- Built-in arc fault protection and rapid shutdown
- Built-in PID mitigation for maximized system performance
- Monitored\* and field-replaceable surge protection devices, to better withstand surges caused by lightning or other events
- Built-in module-level monitoring with Ethernet or cellular communication for full system visibility

\*Applicable only for DC and AC SPDs

# / Three Phase Inverter with Synergy Technology

For the 277/480V Grid for North America

SE80KUS / SE100KUS / SE110KUS / SE120KUS

MODEL NUMBER	SE80KUS	SE100KUS	SE110KUS	SE120KUS	
APPLICABLE TO INVERTERS WITH PART NUMBER	SExxK-USx8lxxxx				UNITS
<b>OUTPUT</b>					
Rated AC Active Output Power	80000	100000	110000	120000	W
Maximum AC Apparent Output Power	80000	100000	120000	120000	VA
AC Output Line Connections	3W + PE, 4W + PE				
Supported Grids	WYE: TN-C, TN-S, TN-C-S, TT, IT; Delta: IT				
AC Output Voltage Minimum-Nominal-Maximum <sup>(1)</sup> (L-N)	244 – 277 – 305				Vac
AC Output Voltage Minimum-Nominal-Maximum <sup>(1)</sup> (L-L)	422.5 – 480 – 529				Vac
AC Frequency Min-Nom-Max <sup>(1)</sup>	59.5 – 60 – 60.5				Hz
Maximum Continuous Output Current (per Phase, PF=1)	96.5	120	144.3		Aac
GFDI Threshold	1				A
Utility Monitoring, Islanding Protection, Configurable Power Factor, Country Configurable Thresholds	Yes				
Total Harmonic Distortion	≤ 3				%
Power Factor Range	+/-0.2 to 1				
<b>INPUT</b>					
Maximum DC Power (Module STC) Inverter / Synergy Unit	140000 / 70000	175000 / 58300	210000 / 70000		W
Transformer-less, Ungrounded	Yes				
Maximum Input Voltage DC+ to DC-	1000				Vdc
Operating Voltage Range	850 – 1000				Vdc
Maximum Input Current	2 x 48.25	3 x 40	3 x 48.25		Adc
Reverse-Polarity Protection	Yes				
Ground-Fault Isolation Detection	167kΩ sensitivity per Synergy Unit <sup>(2)</sup>				
CEC Weighted Efficiency	98.5				%
Nighttime Power Consumption	< 8	< 12			W
<b>ADDITIONAL FEATURES</b>					
Supported Communication Interfaces <sup>(3)</sup>	2 x RS485, Ethernet, Wi-Fi (optional), Cellular (optional)				
Smart Energy Management	Export Limitation				
Inverter Commissioning	With the SetApp mobile application using built-in Wi-Fi access point for local connection				
Arc Fault Protection	Built-in, User Configurable (According to UL1699B)				
Photovoltaic Rapid Shutdown System	EC 2014, 2017 and 2020, Built-in				
PID Rectifier	Nighttime, built-in				
RS485 Surge Protection (ports 1+2)	Type II, field replaceable, integrated				
AC, DC Surge Protection	Type II, field replaceable, integrated				
DC Fuses (Single Pole)	25A, integrated				
<b>DC SAFETY SWITCH</b>					
DC Disconnect	Built-in				
<b>STANDARD COMPLIANCE</b>					
Safety	UL1699B, UL1741, UL1741 SA, UL1741 SB, UL1998, CSA C22.2#107.1, Canadian AFCI according to T.I.L. M-07				
Grid Connection Standards	IEEE 1547-2018, Rule 21, Rule 14 (HI)				
Emissions	FCC part 15 class A				

(1) For other regional settings please contact SolarEdge support.

(2) Where permitted by local regulations.

(3) For specifications of the optional communication options, visit the [Communication product page](#) or the [Resource Library](#) to download the relevant product datasheet.



# / Three Phase Inverter with Synergy Technology

For the 277/480V Grid for North America

SE80KUS / SE100KUS / SE110KUS / SE120KUS

MODEL NUMBER	SE80KUS	SE100KUS	SE110KUS	SE120KUS
APPLICABLE TO INVERTERS WITH PART NUMBER	SExxK-USx8Lxxxx			UNITS
INSTALLATION SPECIFICATIONS				
Number of Synergy Units per Inverter	2	3		
Ac Max Conduit Size	2 1/2"			in
Max AWG Line / PE	4/0 / 1/0			
DC Max Conduit Size	1 x 3"; 2 x 2"			in
DC Input Inverter/ Synergy Unit	8 / 4 pairs; 6-12 AWG	12 / 4 pairs; 6-12 AWG		
	2 pairs / 1 pair, Max 2 AWG; copper or aluminum	3 pairs / 1 pair, Max 2 AWG; copper or aluminum		
Dimensions (H x W x D)	Synergy Unit: 22 x 12.9 x 10.75 / 558 x 328 x 273 Synergy Manager: 14.17 x 22.4 x 11.6 / 360 x 560 x 295			in / mm
Weight	Synergy Unit: 70.4 / 32 Synergy Manager: 39.6 / 18			lb / kg
Operating Temperature Range	-40 to +140 / -40 to +60 <sup>(4)</sup>			°F / °C
Cooling	Fan (user replaceable)			
Noise	< 67			dBA
Protection Rating	NEMA 3R			
Mounting	Brackets provided			

(4) For power de-rating information refer to the [Temperature De-rating - Technical Note \(North America\)](#).

# DRY TYPE TRANSFORMER SPECIFICATION

## TRANSFORMER SPECIFICATION

RATING	500kVA
COOLING	ANN
TEMPERATURE RISE	115°C
PHASES	3
FREQUENCY	60Hz
K-FACTOR	4

	PRIMARY	SECONDARY
VOLTAGE	600V	480Y/277V
TAPS - FCAN	2 x 2.5%	-
TAPS - FCBN	2 x 2.5%	-
BIL	10kV	10kV

CONDUCTOR	ALUMINUM
WINDINGS	POLYESTER RESIN DIPPED
INSULATION CLASS	220°C
IMPEDANCE (@ 135°C)	4.0% - 6.0%
MIN EFFICIENCY	99.14% @ 35% LOAD, 75°C
AVG. SOUND LEVEL	60dBA
ELECTROSTATIC SHIELD	NONE
EST. WEIGHT	3860 lbs [1755kg]

## TERMINALS AND CABLE LUGS

	PRIMARY	SECONDARY
LOCATION	FRONT	REAR
LINE LUGS (/PH)	PADS	PADS
NEUTRAL LUGS	N/A	PADS
GROUND LUG	300 MCM-6 AWG LUG ON ENCLOSURE BASE	

## WIRING / CONNECTIONS

PRIMARY: H1-H2-H3		
VOLTAGE	% TAP	LINKS:
630	105.0%	1-2
615	102.5%	2-3
600	100.0%	3-4
585	97.5%	4-5
570	95.0%	5-6

  

SECONDARY: X0-X1-X2-X3		
VOLTAGE	PHASE	CONNECT LOAD TO
480	3	X1-X2-X3
277	1	X0-X1, X0-X2, AND/OR X0-X3

## FEATURES

- NEOPRENE ANTI-VIBRATION PADS INSTALLED BETWEEN CORE & COIL AND ENCLOSURE BASE
- LUG FOR EARTH GROUNDING PROVIDED
- SUITABLE FOR NON-SINUSOIDAL CURRENT LOAD WITH K-FACTOR NOT TO EXCEED 4
- NEUTRAL SIZED FOR 200% OF LINE CURRENT
- SEISMIC RATED FOR USA ZONE 4 AND CANADA ZONE 6
- CSA CERTIFIED (FILE # LR34493)
- UL LISTED (FILE # E108255)
- ISO 9001 QUALITY MANAGEMENT SYSTEM
- EFFICIENCY MEETS OR EXCEEDS:
  - CANADA: SOR/DORS/2018-201 (NRCAN 2019)
  - CSA: CSA C802.2-18
  - USA: DOE 10 CFR PART 431:2016-01 (DOE 2016)

1) Location of nameplate and labels for Canada  
 2) Location of nameplate and labels for USA  
 \*Recommended area for side cable entry (7"x50") on either side

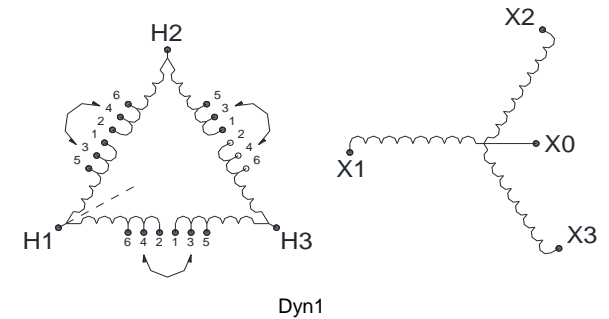
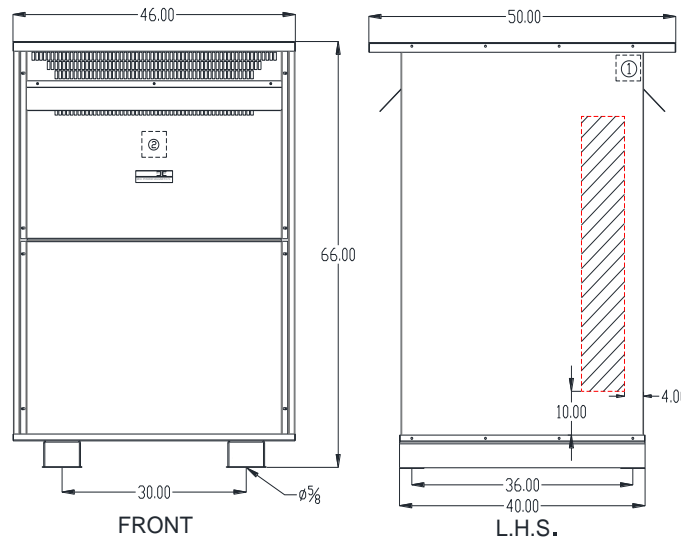

## ENCLOSURE

ENCLOSURE PART #	E3R-10
ENCLOSURE RATING	TYPE 3R (INDOOR)*
CONSTRUCTION	VENTILATED
MATERIAL	STEEL
FINISH	POLYESTER POWDER COAT
COLOR	ANSI/ASA 61 (GREY)
MOUNTING	FLOOR

\*SPRINKLERPROOF WHEN THE ANGLE BETWEEN SPRINKLER HEADS AND OPENING IN THE ENCLOSURE DOES NOT EXCEED 45 DEGREE FROM THE VERTICAL.

\*FOR PROPER VENTILATION FOR FLOOR INSTALLATION KEEP AT LEAST 6 INCHES FROM ADJACENT WALLS

REV	REMARKS	BY	DATE	PRELIMINARY DRAWING	PRODUCT	K-FACTOR RATED ISOLATION TRANSFORMER
				THIS DRAWING MAY NOT TRULY REFLECT OUR FINAL DESIGN. ANY ORDER(S) MUST BE ACCOMPANIED BY OR REFER TO THIS DRAWING. REX POWER MAGNETICS RESERVES THE RIGHT TO CHANGE OR REVISE THESE SPECIFICATIONS WITHOUT NOTICE	MODEL / CAT No.	BA500J-P/K4/T115/Z3
					CUSTOMER	-
					PO #	-
					SWO #	- QTY -
					Prepared By	C.G. Date 9/21/2020
					Approved By	Date -



# Heavy Duty Safety Switches

Selection



System	Ampere Rating	Indoor — Type 1		Outdoor — Type 3R		Horsepower Rating <sup>Ⓞ</sup>								250 Volt DC	600 Volt DC
		Catalog Number	Ship Wt. (lbs.) Std. Pkg	Catalog Number	Ship Wt. (lbs.) Std. Pkg	480V AC		600V AC		250 Volt DC	600 Volt DC				
						1-Phase, 2-Wire	3-Phase, 3-Wire	1-Phase, 2-Wire	3-Phase, 3-Wire						

## 600 Volt Fusible<sup>Ⓢ</sup>

### 2-Pole, 2-Fuse<sup>Ⓢ</sup>

Ampere Rating	Catalog Number	Ship Wt. (lbs.) Std. Pkg	Catalog Number	Ship Wt. (lbs.) Std. Pkg	480 Volt AC/600 Volt AC/600 Volt DC									
					1-Phase, 2-Wire	3-Phase, 3-Wire	1-Phase, 2-Wire	3-Phase, 3-Wire	250 Volt DC	600 Volt DC				
30	HF261	15	HF261R	15	3	7½	—	—	3	10	—	—	5	15
60	HF262	20	HF262R	20	5	20	—	—	10	25	—	—	10	30
100	HF263	26	HF263R	27	10	30	—	—	15	40	—	—	20	50

### 3-Pole, 3-Fuse

Ampere Rating	Catalog Number	Ship Wt. (lbs.) Std. Pkg	Catalog Number	Ship Wt. (lbs.) Std. Pkg	480 Volt AC/600 Volt AC/250 Volt DC <sup>Ⓢ</sup>									
					1-Phase, 2-Wire	3-Phase, 3-Wire	1-Phase, 2-Wire	3-Phase, 3-Wire	250 Volt DC	600 Volt DC				
30	HF361	14	HF361R	15	3	7½	5	15	3	10	7½	20	5	—
30	HF361L <sup>Ⓢ</sup>	19	HF361RL <sup>Ⓢ</sup>	20	3	7½	5	15	3	10	7½	20	5	—
60	HF362	19	HF362R	20	5	20	15	30	10	25	15	50	10	30 <sup>Ⓢ</sup>
60	—	—	HF362RL <sup>Ⓢ</sup>	25	5	20	15	30	10	25	15	50	10	30 <sup>Ⓢ</sup>
100	HF363	24	HF363R	25	5	20	25	60	15	40	30	75	20	50 <sup>Ⓢ</sup>
200	HF364	48	HF364R	49	25	50	50	125	30	50	60	150	40	50
400	HF365A <sup>Ⓢ</sup>	93	HF365RA <sup>Ⓢ</sup>	157	—	—	100	250	—	—	125	350	50	—
600	HF366A <sup>Ⓢ</sup>	98	HF366RA <sup>Ⓢ</sup>	161	—	—	150	400	—	—	200	500	50	—
800	HF367	365	HF367R	365	—	—	200	500	—	—	250	500	50	—
1200	HF368	383	HF368R	385	—	—	200	500	—	—	250	500	50	—

### 3-Pole, 3-Fuse and Solid Neutral

Ampere Rating	Catalog Number	Ship Wt. (lbs.) Std. Pkg	Catalog Number	Ship Wt. (lbs.) Std. Pkg	480 Volt AC/600 Volt AC/250 Volt DC <sup>Ⓢ</sup>									
					1-Phase, 2-Wire	3-Phase, 3-Wire	1-Phase, 2-Wire	3-Phase, 3-Wire	250 Volt DC	600 Volt DC				
30	HF361N	14	HF361NR	15	3	7½	5	15	3	10	7½	20	5	—
60	HF362N	19	HF362NR	20	5	20	15	30	10	25	15	50	10	30 <sup>Ⓢ</sup>
100	HF363N	25	HF363NR	26	10	30	25	60	15	40	30	75	20	50 <sup>Ⓢ</sup>
200	HF364N	49	HF364NR	50	25	50	50	125	30	50	60	150	40	50
400	HF365NA	94.6	HF365NRA	94.6	—	—	100	250	—	—	125	350	50	—
600	HF366NA	99.6	HF366NRA	99.6	—	—	150	400	—	—	200	500	50	—
800	HF367N	375	HF367NR	375	—	—	250	500	—	—	250	500	50	—
1200	HF368N	395	HF368NR	388	—	—	250	500	—	—	250	500	50	—

## 600 Volt Fusible<sup>Ⓢ</sup> (For 2-Pole Applications use outside poles of 3-Pole Switches)

### 2-Pole, 2-Fuse<sup>Ⓢ</sup>

Ampere Rating	Type 4/4X Stainless <sup>Ⓢ</sup>		Type 12 Industrial <sup>Ⓢ</sup>		480 Volt AC/600 Volt AC/600 Volt DC									
	Catalog Number	Ship Wt. (lbs.) Std. Pkg	Catalog Number	Ship Wt. (lbs.) Std. Pkg	1-Phase, 2-Wire	3-Phase, 3-Wire	1-Phase, 2-Wire	3-Phase, 3-Wire	250 Volt DC	600 Volt DC				
30	HF261S	15	HF261J■	15	3	7½	—	—	3	10	—	—	5	15
60	HF262S	20	HF262J■	20	5	20	—	—	10	25	—	—	10	30
100	HF263S■	27	HF263J■	27	10	30	—	—	15	40	—	—	20	50

### 3-Pole, 3-Fuse

Ampere Rating	Catalog Number	Ship Wt. (lbs.) Std. Pkg	Catalog Number	Ship Wt. (lbs.) Std. Pkg	480 Volt AC/600 Volt AC/250 Volt DC <sup>Ⓢ</sup>									
					1-Phase, 2-Wire	3-Phase, 3-Wire	1-Phase, 2-Wire	3-Phase, 3-Wire	250 Volt DC	600 Volt DC				
30	HF361S	13	HF361J	14	—	—	5	15	—	—	7½	20	5	—
60	HF362S	20	HF362J	20	—	—	15	30	—	—	15	50	10	30 <sup>Ⓢ</sup>
100	HF363S	25	HF363J	25	—	—	25	60	—	—	30	75	20	50 <sup>Ⓢ</sup>
200	HF364S	49	HF364J	49	—	—	50	125	—	—	60	150	40	50
400	HF365SA <sup>Ⓢ</sup>	93	HF365JA <sup>Ⓢ</sup>	93	—	—	100	250	—	—	125	350	50	—
400	HF365SSA	93	—	—	—	—	100	250	—	—	125	350	50	—
600	HF366SA <sup>Ⓢ</sup>	98	HF366JA <sup>Ⓢ</sup>	98	—	—	150	400	—	—	200	500	50	—
600	HF366SSA	98	—	—	—	—	150	400	—	—	200	500	50	—
800	HF367S	370	HF367J■	365	—	—	200	500	—	—	250	500	50	—
1200	HF368S■	388	HF368J■	388	—	—	250	500	—	—	250	500	50	—

■ Built to order. Allow 3-5 weeks for delivery.

Ⓢ 60-600A 3-Pole switches are also rated 600V DC.

Ⓢ Height reduced switch (45.25 rather than 56 inches in height) for use with 500MCM or smaller conductors.

Ⓢ Use 3-Pole switch for 200A applications.

Ⓢ Dual horsepower ratings: Std.- applies when non-time delay fuses are installed. Max.- applies when time-delay fuses are installed.

Ⓢ Suitable for use as service entrance equipment except on 1200 Amp solidly grounded wye systems per NEC 230.95.

Ⓢ Also rated Type 3S/3R.

Ⓢ Indicates oversized enclosure (30A switch with 60A lugs in a 60A enclosure or 60A switch with 100A lugs in a 100A enclosure).

Ⓢ 600V DC & 600V DC horsepower rating shown requires (2) poles to be connected in series.

Ⓢ 304 grade stainless steel. For switches with enclosures constructed from 316 grade stainless steel, see page 4-18.

# General and Heavy Duty Safety Switches

Dimensions

## Safety Switch Dimensions (Inches)\* & Shipping Weights

Catalog Number	Height			Width		Depth		Knockout Diagram <sup>①</sup>	Shipping Weight (lbs.)
	Box A	With Door B	With Rain Shed C	Box D	With Handle E	Box F	With Handle G		
HF362J, JW	16.27	19.31	—	9.17	11.47	5.33	10.46	—	20
HF362N	16.26	17.46	—	9.15	11.53	5.05	10.17	S16	19
HF362NR	16.26	—	17.77	9.16	11.53	5.05	10.17	S17	20
HF362R, RPV, RPVPG, RW	16.26	—	17.77	9.16	11.53	5.05	10.17	S17	20
HF362RL	21.95	—	23.46	9.64	11.97	5.05	10.17	S11	25
HF362S, SS, SSW, SW	16.27	19.31	—	9.17	11.47	5.33	10.46	—	20
HF363, PV, PVP	21.95	23.15	—	9.64	12.01	5.05	10.17	S10	24
HF363J, JW	21.96	23.16	—	9.65	12.02	5.34	10.46	—	25
HF363N	21.95	23.15	—	9.64	12.01	5.05	10.17	S10	25
HF363NR	21.95	—	23.46	9.64	11.97	5.05	10.17	S11	26
HF363R, RPV, RPVPG	21.95	—	23.46	9.64	11.97	5.05	10.17	S11	25
HF363S, SS, SSW, SW	21.96	23.16	—	9.65	12.02	5.34	10.46	—	25
HF364, PV, PVP	29.9	31.07	—	14.62	16.98	6.36	12.33	S12	48
HF364J, JW	29.96	31.07	—	14.62	16.95	6.63	12.58	—	49
HF364N	29.9	31.07	—	14.62	16.98	6.36	12.33	S12	49
HF364NR	29.9	—	31.42	14.61	16.99	6.36	12.33	S13	48
HF364R, RPV, RPVPG	29.9	—	31.42	14.61	16.99	6.36	12.33	S13	49
HF364S, SS, SSW, SW	29.96	31.07	—	14.62	16.95	6.63	12.58	—	49
HF365A	45.32	45.81	—	22.4	23.404	6.94	9.93	S18	93
HF365JA, HF365JWA	45.32	45.81	—	22.4	23.404	6.97	10.05	—	93
HF365NA	45.32	45.81	—	22.4	23.404	6.94	9.93	S18	94.6
HF365NRA	45.32	45.81	—	22.4	23.404	6.94	9.93	S19	94.6
HF365RA	45.32	45.81	—	22.4	23.404	6.94	9.93	S19	93
HF365SA, HF365SWA	45.32	45.81	—	22.4	23.404	7.34	10.347	—	93
HF365SSA, HF365SSWA	45.32	45.81	—	22.4	23.404	7.34	10.347	—	93
HF366A	45.32	45.81	—	22.4	23.404	6.94	9.93	S18	98
HF366JA, HF366JWA	45.32	45.81	—	22.4	23.404	6.97	10.05	—	98
HF366NA	45.32	45.81	—	22.4	23.404	6.94	9.93	S18	99.6
HF366NRA	45.32	45.81	—	22.4	23.404	6.94	9.93	S19	99.6
HF366RA	45.32	45.81	—	22.4	23.404	6.94	9.93	S19	98
HF366SA	45.32	45.81	—	22.4	23.404	7.34	10.347	—	98
HF366SSA	45.32	45.81	—	22.4	23.404	7.34	10.347	—	98
HF367	66.67	67.16	—	38.4	39.96	9.24	14.68	—	380
HF367J	66.67	67.16	—	38.4	39.96	9.24	14.68	—	380
HF367N	66.67	67.16	—	38.4	39.96	9.24	14.68	—	382
HF367NR	66.67	—	67.74	38.4	40.25	9.24	14.68	—	386
HF367R	66.67	—	67.74	38.4	40.25	9.24	14.68	—	382
HF367S	66.67	67.16	—	38.4	39.96	9.24	14.68	—	380
HF368, J, S	66.67	67.16	—	38.4	39.96	9.24	14.68	—	383
HF368N	66.67	67.16	—	38.4	39.96	9.24	14.68	—	385
HF368NR	66.67	—	67.74	38.4	40.25	9.24	14.68	—	388
HF368R	66.67	—	67.74	38.4	40.25	9.24	14.68	—	385
HNF365JA	45.32	45.81	—	22.4	23.404	6.97	10.05	—	75
HNF365RA	33.47	33.96	—	22.4	23.404	6.94	9.93	S19	75
HNF365SA	33.47	33.96	—	22.4	23.404	7.34	10.347	—	75
HNF365SSA	33.47	33.96	—	22.4	23.404	7.34	10.347	—	75
HNF366SA	33.47	33.96	—	22.4	23.404	7.34	10.347	—	77
HNF366SSA	33.47	33.96	—	22.4	23.404	7.34	10.347	—	77
HNF366JA	45.32	45.81	—	22.4	23.404	6.97	10.05	—	77
HNF366RA	33.47	33.96	—	22.4	23.404	6.94	9.93	S19	77
HNF361, PV, PVP also HNF261 & HNF362H	11.11	12.31	—	6.64	9.01	5.05	10.17	S7	12
HNF361J, JW also HNF261J & HNF362JH	11.12	14.14	—	6.65	9.02	5.56	10.46	—	13
HNF361R, RPV, RPVPG also HNF261R & HNF362RH	11.11	—	12.63	6.64	9.01	5.05	10.17	S9	13
HNF361RL	16.26	—	17.77	9.16	11.53	5.05	10.17	S17	20
HNF361S, SS, SSW, SW also HNF261S & HNF362SH	11.12	14.14	—	6.65	9.02	5.56	10.46	—	13
HNF362, PV, PVP also HNF262	16.26	17.46	—	9.15	11.53	5.05	10.17	S16	18
HNF362J, JW also HNF262J	16.27	17.46	—	9.17	11.47	5.33	10.46	—	19
HNF362R, RPV, RPVPG also HNF262R	16.26	—	17.77	9.16	11.53	5.05	10.17	S17	19
HNF362RL	21.95	—	23.46	9.64	11.97	5.05	10.17	S11	24
HNF362S, SS, SSW, SW also HNF262S	16.27	17.46	—	9.17	11.47	5.33	10.46	—	19
HNF363, PV, PVP also HNF263	21.95	23.15	—	9.64	12.01	5.05	10.17	S10	23
HNF363J, JW also HNF263J	21.96	23.16	—	9.65	12.02	5.34	10.46	—	24
HNF363R, RPV, RPVPG also HNF263R	21.95	—	23.46	9.64	11.97	5.05	10.17	S11	24
HNF363S, SS, SSW, SW also HNF263S	21.96	23.16	—	9.65	12.02	5.34	10.46	—	24

\*For inches / millimeters conversion, multiply inches by 25.4.

① Knocks not provided on Type 4 / 4X and 12 or in 800 & 1200A switches.

# Application

## Type P4 Panelboards

**Table P4-3 – Main Breaker Selection**

Ampere rating	Breaker type			Maximum IC (KA) Symmetrical Amperes			Main Breaker Unit Space in inches (mm)	Continuous Current Rating
	Trip type <sup>1</sup>	Frame type	Breaker family	240V	480V	600V		
400A	TMTU	JXD6, JD6	Sentron	65	35	22	8.75 (222)	200, 225, 250, 300, 350, 400
		HJXD6, HJD6	Sentron	100	65	35	8.75 (222)	200, 225, 250, 300, 350, 400
		HHJXD6, HHJD6	Sentron	200	100	50	8.75 (222)	200, 225, 250, 300, 350, 400
		CJD6	Sentron	200	150	100	8.75 (222)	200, 225, 250, 300, 350, 400
	ETU	NJ	VL	65	35	25	6.25 (159)	250, 400
		SJD6	Sentron	65	35	25	8.75 (222)	200, 300, 400
		HJ	VL	100	65	25	6.25 (159)	250, 400
		SHJD6	Sentron	100	65	35	8.75 (222)	200, 300, 400
		LJ	VL	200	100	25	6.25 (159)	250, 400
		SCJD6	Sentron	200	150	100	8.75 (222)	200, 300, 400
600A	TMTU	LXD6	Sentron	65	35	25	8.75 (222)	450, 500, 600
		LD6	Sentron	65	35	25	8.75 (222)	250, 300, 350, 400, 450, 500, 600
		HLXD6, HLD6	Sentron	100	65	35	8.75 (222)	250, 300, 350, 400, 450, 500, 600
		HHLXD6, HHLD6	Sentron	200	100	50	8.75 (222)	250, 300, 350, 400, 450, 500, 600
		CLD6	Sentron	200	150	100	8.75 (222)	250, 300, 350, 400, 450, 500, 600
	ETU	NL <sup>2</sup>	VL	65	35	18	6.25 (159)	400, 600
		SLD6	Sentron	65	35	25	8.75 (222)	300, 400, 500, 600
		HL <sup>2</sup>	VL	100	65	18	6.25 (159)	400, 600
		SHLD6	Sentron	100	65	35	8.75 (222)	300, 400, 500, 600
		LL <sup>2</sup>	VL	200	100	18	6.25 (159)	400, 600
SCLD6	Sentron	200	150	100	8.75 (222)	300, 400, 500, 600		
800A	TMTU	NM <sup>3</sup>	VL	65	35	25	8.75 (222)	600, 700, 800
		HM <sup>3</sup>	VL	100	65	35	8.75 (222)	600, 700, 800
		LM <sup>3</sup>	VL	200	100	50	8.75 (222)	600, 700, 800
	ETU	NM <sup>3</sup>	VL	65	35	25	8.75 (222)	600, 800
		HM <sup>3</sup>	VL	100	65	35	8.75 (222)	600, 800
		LM <sup>3</sup>	VL	200	100	50	8.75 (222)	600, 800

<sup>1</sup> TMTU = Thermal Magnetic Trip Unit and ETU = Electronic Trip Unit.

<sup>2</sup> 100% ratings are not available for the VL LG frame, replace with VL MG frame @ 600A rated 100%.

<sup>3</sup> 100% ratings are not available for the VL MG. Use a P5 panel for this application with the VL NG frame @ 800A rated 100%.

**Table P4-4 – Enclosure Selection <sup>1</sup>**

Enclosure Dimension in Inches (mm)			Available Unit Space in Inches (mm) Dimension "C" in Fig. 4-1		
H	W	D	Main Lug Only	Main Breaker	800A
			400 / 800A	400A/600A	
60 (1524)	32 (813)	10 (254)	30 (762)	23.75 (603)	21.25 (540)
75 (1905)	32 (813)	10 (254)	45 (1143)	38.75 (984)	26.25 (921)
90 (2286)	32 (813)	10 (254)	60 (1524)	53.75 (1365)	51.25 (1302)

<sup>1</sup> Standard trim is four piece without door. Surface or flush one piece trim is available for 32 in. (813 mm) wide circuit breaker panels.

**Table P4-5 – Main Breaker Lug Location Reference (Fig. P4-1)**

Ampere Rating	Breaker Type	Dimensions in Inches (mm)	
		A	B
400	JXD6, JD6, HJXD6, HJD6	10.425 (265)	13.125 (333)
400	HHJXD6, HHJD6		
400	NJ, HJ, LJ		
400	SJD6, SHJD6		
400	CJD6, SCJD6		
600	LXD6, LD6, HLXD6, HLD6, HHLXD6, HHLD6		
600	NL, HL, LL		
600	SLD6, SHLD6		
600	CLD6, SCLD6		
800	NM, HM, LM,		

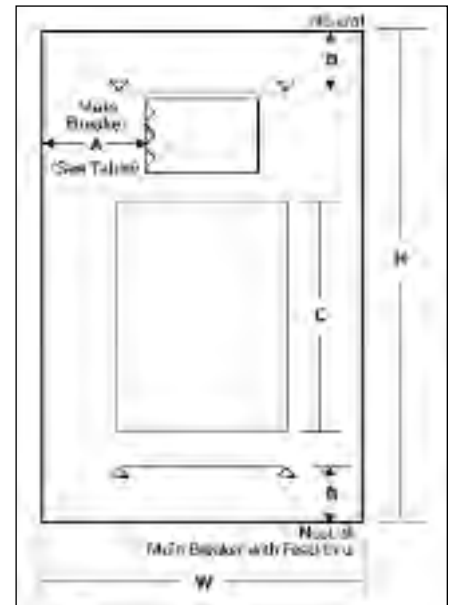
**Fig. P4-1**

# Dimensions

## Type P4 Panelboards

### Type 1 Box

Box is symmetrical

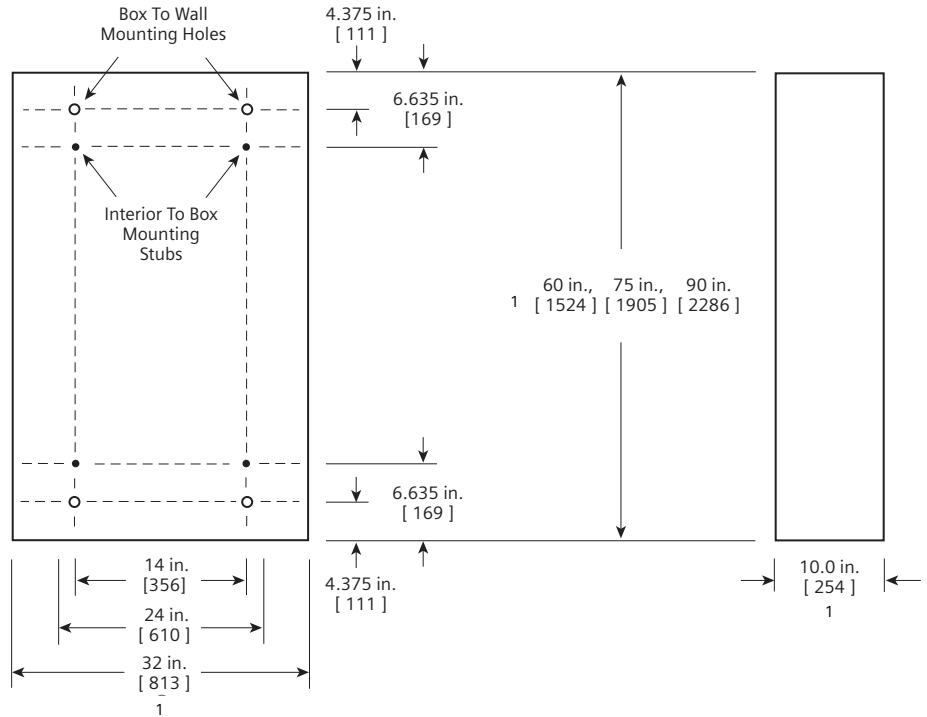
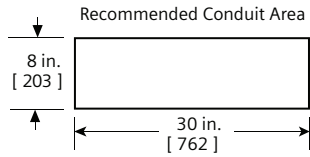

### Type 3R and 3R/12 Box

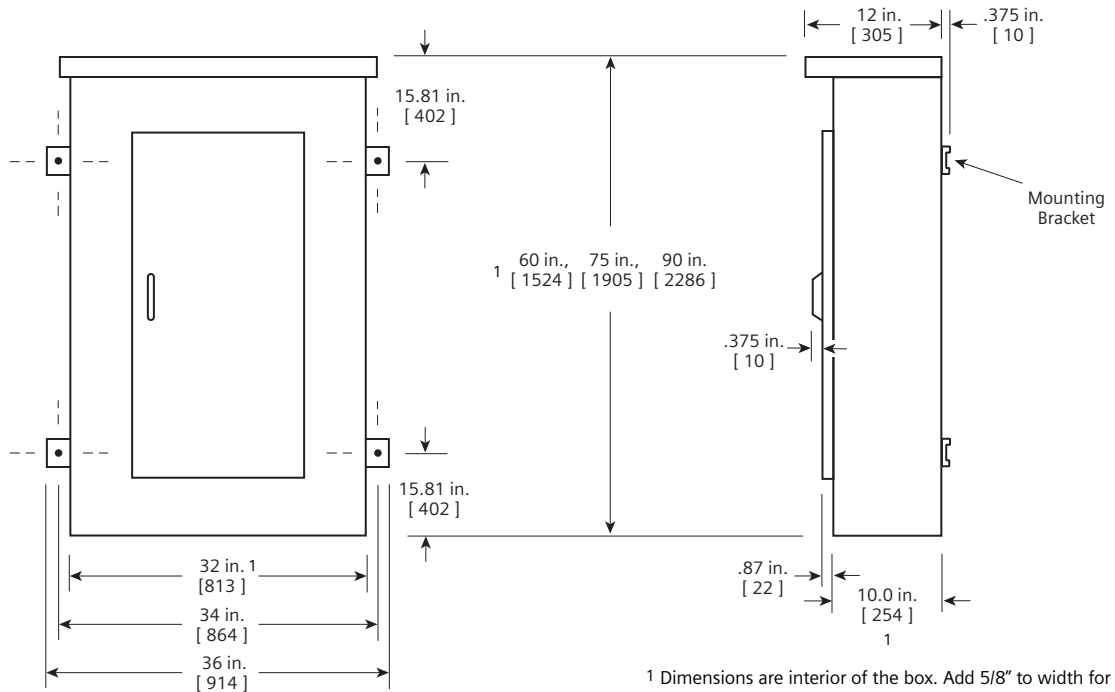

<sup>1</sup> Dimensions are interior of the box. Add 5/8" to width for absolute dimension. Add 1/8" to height for absolute dimension.

Dimensions shown in inches and millimeters [ ].