

QUICK INSTALLATION MANUAL
ROUTER TIREL2
PRODUCT CODE: ZR-TIREL2-EM
ROUTER FOR ZB-CONNECTION RADIO NETWORK

1) GENERAL DEVICE CHARACTERISTICS

Router TIREL2 device (ZR-TIREL2-EM) is part of the family of wireless radio devices ZB-CONNECTION. It has a thermal sensor input, two digital inputs and two relay outputs. It has the fundamental task of acquiring its inputs, actuating an regulation process that allows it to manage its relays and sending the data it acquires and generates at regular intervals, to a compatible Gateway. The device requires an uninterruptible 24 Vdc (or 24 V ac) power supply. For network purposes, it is a Router i.e. it has the active function of maintaining radio traffic from and to other similar devices and it can also act as a parent device for battery-powered nodes of the same family.

2) DEVICE ELECTRICAL CHARACTERISTICS

POWER SUPPLY: 24Vdc ($\pm 10\%$); 100mA
 24Vac ($\pm 10\%$); 50/60Hz; 2,4VA

WIRELESS CHARACTERISTICS: 2405 MHz \div 2480 MHz
 DSSS Modulation
 Nominal transmission Power 0 dBm
 IEEE 802.15.4 compliant
 Stack EmberZNet3.5.0
 Stack version 0
 Proprietary profile ID
 Proprietary encryption key

THERMAL SENSOR INPUT: NTC type sensor - type 103AT (R25 = 10 KOhm; Beta = 3435K)
 Measurement range -50°C - $+50^{\circ}\text{C}$
 Reading resolution 0.1°C - Reading precision $\pm 0.5^{\circ}\text{C}$
 not insulated inputs for clean contact

DIGITAL INPUT CHARACTERISTICS: Coil 12Vdc

RELAY CHARACTERISTICS: Contacts 5A 250V

CONNECTIONS: Pull-out terminals (3.81 mm pitch)

PROTECTION CLASS: IP55

3) CIRCUIT BOARD AND CONNECTION LAYOUT

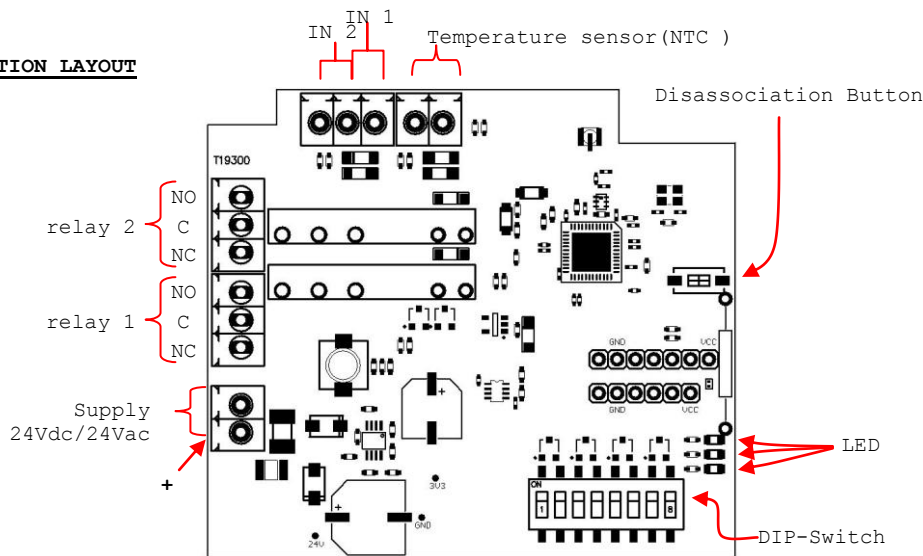

4) DEVICE ADDRESSING

The device can be addressed by a DipSwitch. Valid address ranges between 16 and 127. DipSwitch is read only at the reset event. A modification to DipSwitch position is only taken into consideration after device reset. Set the DipSwitch before switching on the card and before it is inserted into the network.

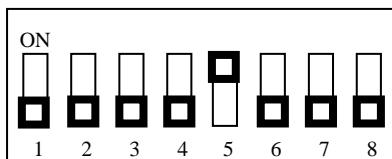

DIP1	DIP2	DIP3	DIP4	DIP5	DIP6	DIP7	DIP8	ADR
OFF	OFF	OFF	OFF	ON	OFF	OFF	OFF	16
ON	OFF	OFF	OFF	ON	OFF	OFF	OFF	17
OFF	ON	OFF	OFF	ON	OFF	OFF	OFF	18
ON	ON	OFF	OFF	ON	OFF	OFF	OFF	19
...
...
OFF	OFF	ON	ON	ON	ON	ON	OFF	124
ON	OFF	ON	ON	ON	ON	ON	OFF	125
OFF	ON	ON	ON	ON	ON	ON	OFF	126
ON	ON	ON	ON	ON	ON	ON	OFF	127

5) ASSOCIATING THE DEVICE TO A COMPATIBLE NETWORK

The process to be followed when annexing the TIREL2 node to a network is the same as for all types of ZB-CONNECTION network routers.

The joining process is activated automatically by the device if the node does not have network parameters, this happens if the device is new or if it has been voluntarily disassociated.

The annexing process consists in scanning all 16 radio channels, in search of an "open" and compatible network (i.e. a ZB-CONNECTION type).

Scanning lasts about 20 seconds. If the annexing process terminates unsuccessfully, the device resets and the annexing process is re-started.

Network opening is performed by suitably stimulating the Gateway, by pressing the push-button onboard the device or sending the appropriate command password (for further information, refer to the document relating to the Gateway).

6) DISASSOCIATING THE DEVICE FROM THE NETWORK

Device disassociation causes the loss of network parameters, with the consequent exiting of the device from the network it belongs to.

In addition to the loss of network parameters, the device loads the default value for each of its operation parameters (HoldingRegister).

Disassociation can be commanded in two ways:

- 1) Receipt of the appropriate command password.
- 2) Holding the pushbutton on the card down for at least 6 seconds. Disassociation using the push-button is only possible within 20 seconds from when the device is switched on.

7) LED/PUSH-BUTTON INTERFACE

TIREL2 has three leds through which it is possible to obtain information on the device's operating state.

Furthermore, the Router-Bridge has a push-button which makes it possible to send commands to the device.

Nomenclature of TIREL2 leds:

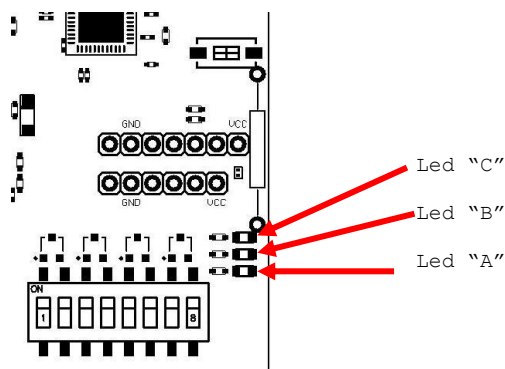

Behaviour of leds at the start-up:

At the reset of TIREL2 all leds lighted for 2 seconds, then all leds flash fast for another 2 seconds.

At the end of flashing device starts the normal functioning.

Leds functioning when device is NOT on the network:

Led "A" on lighted steady, leds "B" and "C" off

Leds functioning when device is on the network:

Led "A": Working State

Slow flashing (1Hz) -> Closed Router

Fast flashing (4Hz) -> Opened Router

Led "B" (middle led): Radio Link

Turned off -> No router with good link in the proximity

1 flash -> One router with good link in the proximity

2 flashes -> Two routers with good link in the proximity

3 flashes -> Four or more routers with good link in the proximity

Led "C": Radio Activity

Usually turned off

Shortly Lighted on transmitting or receiving a radio message