

Integrating Measurements in The MathWorks Inc. MATLAB[®] with the LabVIEW Math Interface Toolkit

National Instruments LabVIEW is the industry-standard software tool for acquiring, analyzing, and presenting data. LabVIEW offers over 400 analysis functions for programmatically extracting information from measurement data. However, certain applications require interactive analysis capabilities for building customized analysis algorithms from a series of primitive commands. Analysis-specific environments such as Xmath, part of [NI MATRIXx](#), and The MathWorks Inc. MATLAB[®] offer algorithm scripting capabilities to interactively design custom analysis routines. However, these analysis environments fall short when attempting to verify the custom analysis routine with real-world data.

The National Instruments Math Interface Toolkit (MIT) allows LabVIEW developers to seamlessly call LabVIEW virtual instruments (VIs) from the MATLAB analysis environment. MIT converts any LabVIEW VI into a MATLAB MEX function, allowing users to call the VI in MATLAB as if it were a native function. Using MIT, LabVIEW developers can leverage industry-leading I/O connectivity to quickly create a data acquisition or instrument control VI which can then be called from MATLAB. In addition, the MIT allows users to take advantage of all LabVIEW functionality, including customizable user interfaces, in a form callable as a native MATLAB function.

This paper provides an introduction to the instrument communication and PC-based hardware acquisition capabilities of LabVIEW, followed by an introduction to the Math Interface Toolkit. The paper then concludes with importing MATLAB script into LabVIEW.

Acquiring Data Using Stand-Alone Instruments

LabVIEW simplifies the process of connecting to and communicating with your stand-alone instruments, regardless of the communication protocol. LabVIEW allows you to easily communicate via GPIB, serial, Ethernet, USB, and FireWire busses with any instrument, including PXI and VXI systems. In addition, the National Instruments Instrument Driver Network (ni.com/idnet) contains LabVIEW instrument drivers for over 1,700 instruments from more than 150 vendors.

Instrument drivers are the key to rapid development of instrument control applications. These drivers are libraries of modular VIs that remove the need for the end user to spend time learning complicated communication protocols and instrument commands. Included in these libraries are not only high-level application VIs, but also full-featured instrument driver component VIs, allowing users to develop their control application in a general structure while also taking advantage of the entire feature set of the instrument. Figure 1 illustrates an application for initializing and reading from a Keithley 2000 multimeter, an example included in the free downloadable driver.

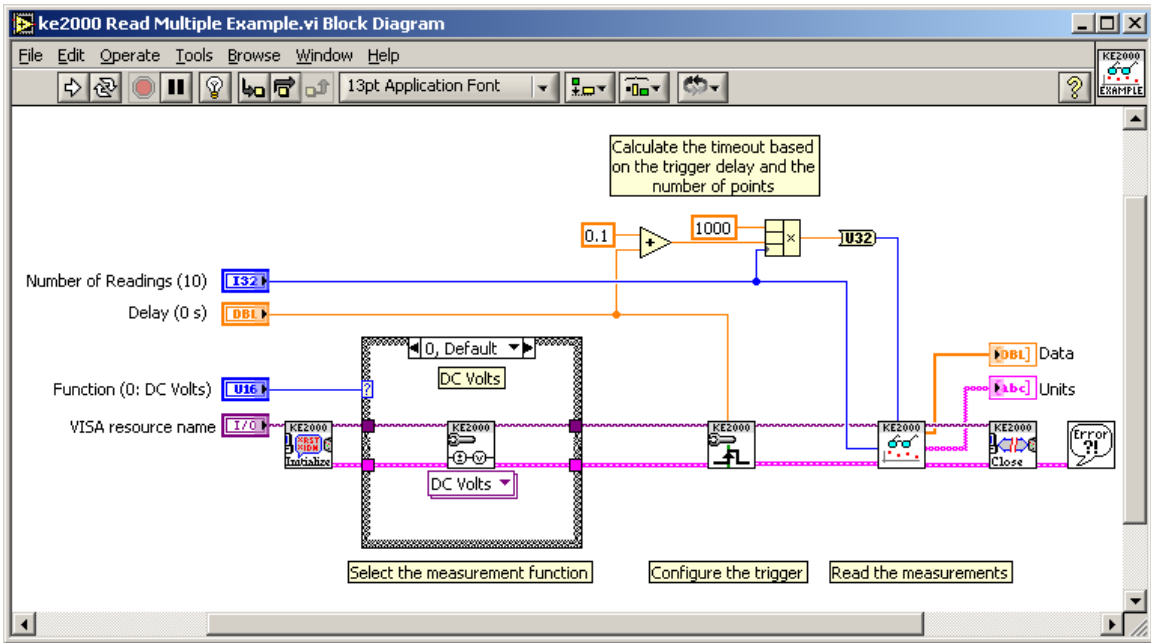

Figure 1. LabVIEW Keithley 2000 Digital Multimeter Driver Example

With LabVIEW 7 Express, NI introduced the Instrument I/O Assistant. Based on Express technology, the Instrument I/O Assistant allows users to interactively create instrument control applications. Using the intuitive wizard, illustrated in Figure 2, users can call a sequence of query commands, visually parse returned data, and automatically generate corresponding LabVIEW code for VISA and GPIB communication.

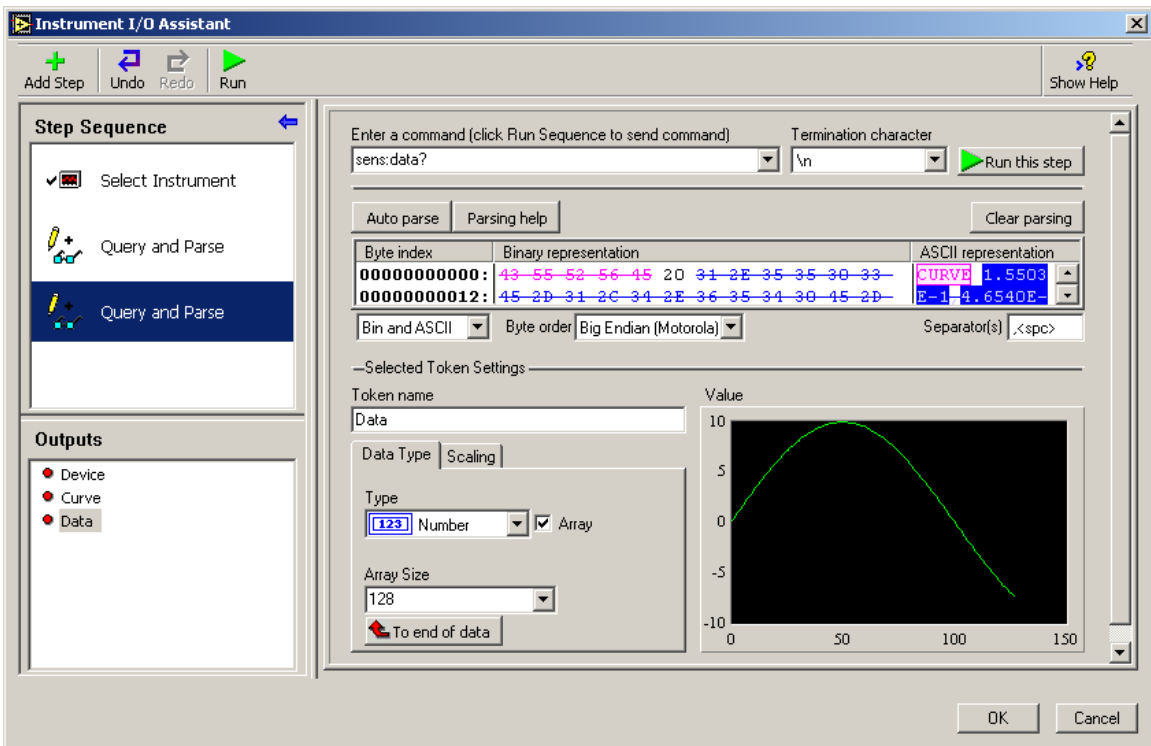

Figure 2. The LabVIEW 7 Instrument I/O Assistant for Interactive Instrument Control

Acquiring Data Using PC-Based Hardware

The concept of virtual instrumentation, leveraging off-the-shelf PC technology and PC-based measurement hardware for a more customizable and cost-effective measurement solution, has revolutionized the process of acquiring real-world data. PC-based data acquisition (DAQ) devices continue to press the limits of acquisition speed and resolution, while offering a more customizable solution through software. LabVIEW offers support for thousands of DAQ devices from multiple vendors, including PCI, PXI, PCMCIA, USB, FireWire, and Ethernet-based devices. LabVIEW device drivers deliver a high-level application program interface (API) that abstracts users from low-level register calls and allows them to focus on their data, not how to acquire it.

Engineers and scientists using National Instruments DAQ hardware can take advantage of additional functionality within LabVIEW to decrease development time and increase the power of their acquisition application. With NI-DAQ 7.0, National Instruments rearchitected our DAQ drivers to offers significant performance and accuracy increases over previous versions. Additionally, LabVIEW 7 Express features interactive, configuration-based data acquisition development through the new DAQ Assistant, shown in Figure 3. Similar to the Instrument I/O Assistant, the DAQ Assistant provides an intuitive, interface-driven wizard through which users can easily configure their data acquisition application and automatically generate the associated LabVIEW code.

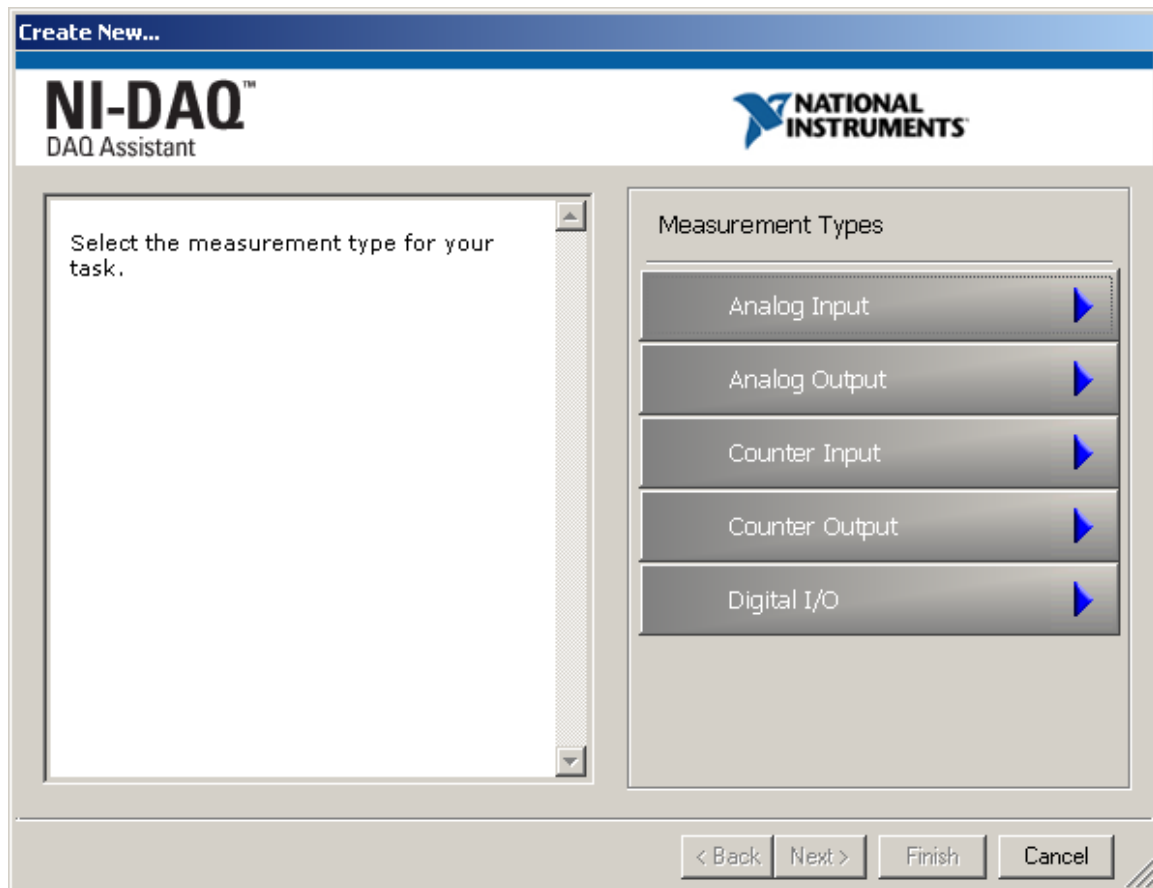

Figure 3. The New DAQ Assistant for Interactive Data Acquisition Development

Bridging LabVIEW and MATLAB with NI Math Interface Toolkit

Verifying the custom analysis algorithm you've built in MATLAB requires importing real-world data. LabVIEW is the most productive tools for acquiring data, and with the Math Interface Toolkit, you can easily import any LabVIEW VI into MATLAB through an intuitive wizard. The MIT packages your VI into a MEX function, a DLL with a unique entry point recognizable by MATLAB. Once in this form, calling your VI is the same as calling any native MATLAB function.

After building your acquisition VI, launch the MIT wizard from the *Tools* menu of LabVIEW. The wizard, as seen in Figure 4, displays the current inputs and outputs of your VI, which will become the input and output parameters of your MEX function. The wizard allows you to customize the name of your MEX function, add or remove input and output parameters, and reorder the parameters to your specifications. The MIT wizard will also automatically generate help documentation for your MEX function, based on VI context help. This documentation can be edited to include additional information.

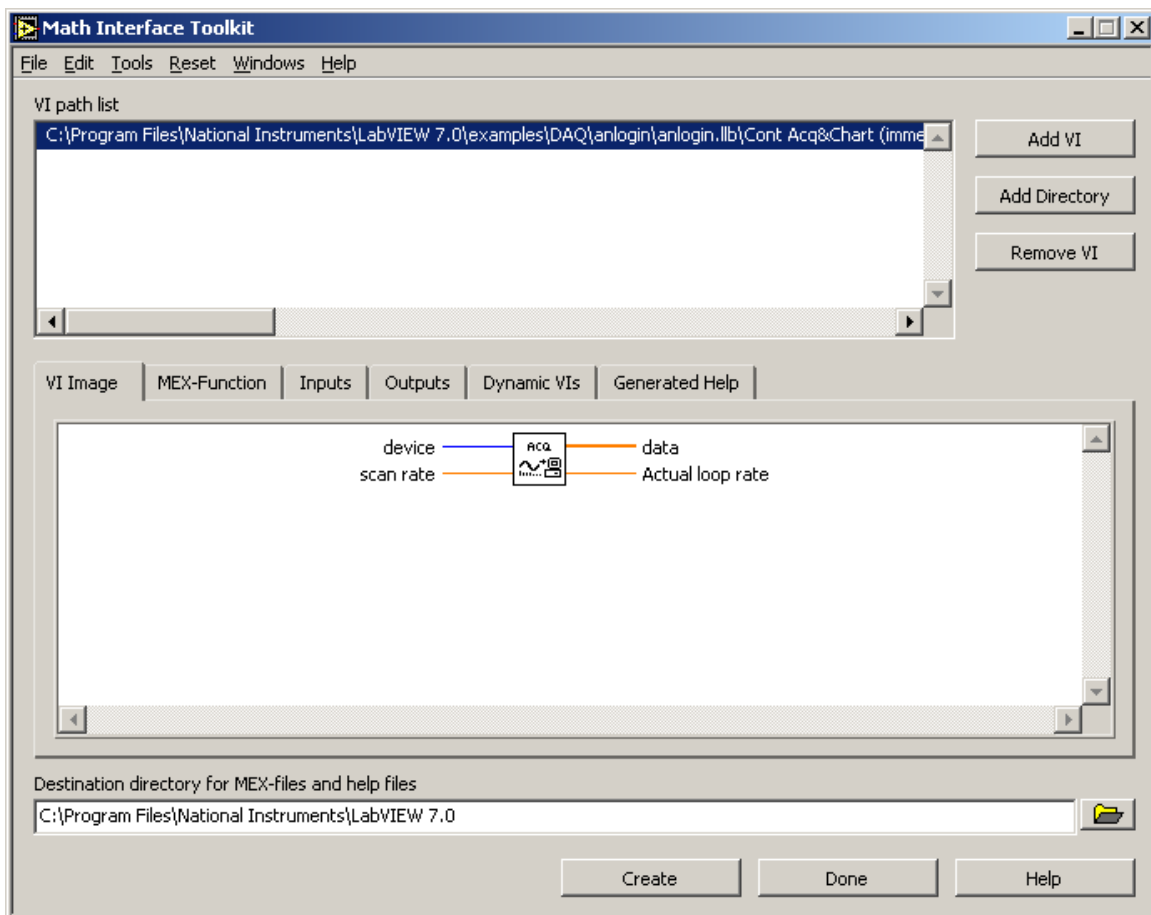

Figure 4. MIT Wizard

MEX functions created from LabVIEW VIs can include much more than the industry-leading I/O capabilities discussed here. Through LabVIEW, users can create interactive user interfaces for their applications that are easily customizable and configurable. These user interfaces are then packaged along with the MEX function and will appear when the function is called in MATLAB. This is particularly useful for continuous data acquisition applications where user input is necessary to dynamically adjust input parameters or stop the acquisition routine.

Completing the Application

Bringing your application full circle requires that you be able to deploy a single application in a single environment, yet your acquisition and presentation components are in LabVIEW and your analysis remains in MATLAB. To simplify the process, LabVIEW provides you with the MATLAB script node, which is included in LabVIEW Full and Professional development systems. This node in the LabVIEW block diagram allows you to cut and paste the analysis script that you customized in the MATLAB environment directly in your LabVIEW block diagram. When executed, LabVIEW passes the included script through an ActiveX interface to MATLAB for execution. Now you can reuse your data acquisition routine, user interface, and additional presentation components, and include your customized analysis through the MATLAB script node.

Conclusion

LabVIEW offers users an intuitive, graphical approach to programmatically acquire, analyze, and visualize data. Certain applications require an interactive approach to data analysis in order to create custom analysis algorithms tailored to unique data sets or applications. While applications such as Xmath and MATLAB are optimized for analysis development, importing real-world data into these environments for verification of these algorithms can be troublesome.

With the LabVIEW Math Interface Toolkit, users leverage powerful LabVIEW applications to bring real-world data into MATLAB for verification of analysis routines. Once these routines have been finalized, the LabVIEW MATLAB script node allows LabVIEW developers to cut and paste custom analysis scripts into the LabVIEW block diagram, building on their original data acquisition routines, and incorporating the web publishing, report generation, and database connectivity capabilities of LabVIEW to complete their measurement application.

For more information on LabVIEW, visit ni.com/labview.

For additional information on the LabVIEW Math Interface Toolkit, visit the [MIT homepage](#).