

The Effects of Electric Currents on ATP Generation, Protein Synthesis, and Membrane Transport in Rat Skin

NGOK CHENG, M.D., HARRY VAN HOOF, M.D., EMMANUEL BOCKX, M.D.,
MICHEL J. HOOGMARTENS, M.D., * JOSEPH C. MULIER, M.D., *
FRANS J. DE DUCKER, PH. D., ** WILLY M. SANSEN, PH. D., ** AND
WILLIAM DE LOECKER, M.D.

Some of the most important electrical changes occurring in living tissues are (1) piezoelectricity, a stress-generated potential,^{2,17,18,26,27,37} (2) pyroelectricity provoked by heating biopolymers,¹⁴ and (3) streaming potentials caused by the movement of charged liquids.¹³ Biological systems are known to be greatly affected by electrical treatment. The growth in higher plants can be stimulated by the application of an electric field,¹⁹ and *in vitro* applied currents may inhibit bacterial growth.³⁵ The application of an electric or an electromagnetic field to various biologic systems results in stimulation of growth and tissue repair.⁴ *In vivo* electromagnetic treatment of bone tissue improves osteogenesis.^{38,39} and has been used in the treatment of nonunion^{7,16} and congenital pseudarthrosis.^{8,28} Electrical potentials also stimulate the regeneration of damaged nerve and muscle structures³⁴ and accelerate surgical wound healing.^{1,9} Electrical stimulation has even been used to treat skin decubitus ulcers.^{42,43} Important advances have been made in the analysis of bioelectricity, particularly by clinical experimentation. Inasmuch as the biologic aspect of bioelectricity has still been insufficiently explored, an attempt is made to analyze and explain some of the biochemical effects that occur in skin tissue during *in vitro* treatment by electric current.

MATERIALS AND METHODS

The skin of locally inbred, male Wistar R rats, just finishing their first hair-cycle at 21 days of age, was used. In these circumstances metabolism of the skins was in rest phase. After removing the hair of the back by plucking and disinfection with 0.05% chlorhexidine (ICI), the skin samples, measuring approximately 5 x 6 cm and 0.5 mm in thickness, were isolated and the subcutaneous fat and connective tissue removed with a scalpel.

This tissue was longitudinally cut in two equal parts; one part was electrically stimulated, and the other served as a nontreated control.

Either the entire skin flap was used or the tissue was partially cut in longitudinal strips (3-5 mm wide), remaining attached at both ends to the communal tissue base.

The skin samples were slightly clamped at both ends between adjustable platinum or stainless steel plate or wire electrodes fixed on a Perspex frame. This entire system, placed in an appropriate plastic container, was submerged in Krebs-Ringer bicarbonate buffer, pH 7.4, containing 100,000 U of penicillin, 100 mg of streptomycin, and 20 mg of gentamycin/100 ml buffer. Direct electric currents varying from 1 μ A to 30,000 μ A, were applied for up to four hours at a constant temperature of 37 °C. The direct current was produced by a locally constructed transistorized current source supplied by two 9-V batteries (Duracell, Mallroy, England) and potentiometrically regulated (Fig. 1).

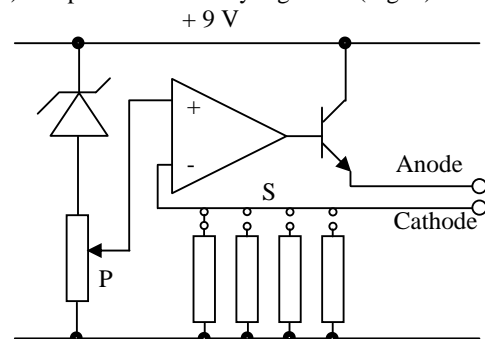

FIG. 1. Electrical circuit of the current source. The direct current is produced by a current source, which is supplied by two 9-V batteries. An operational amplifier (μ P 741) assures each required current to be kept constant. The value of the output current is controlled by potentiometer (P) and range switch (S).

The total electrical resistance of skin was estimated as a function of the various currents applied, using the four-point measuring technique.³⁶ The cross-sectional area of the medium orthogonal to the current direction was 20 cm². To follow the incorporation of amino acids into the proteins, 40 μ Ci of [2-¹⁴C]glycine (specific activity, 48.9 mCi/mmol; The Radio-chemical Centre, Amersham, England), L-[U-¹⁴C]alanine (specific activity 150 mCi/mmol), or L-[U-¹⁴C]isoleucine (specific activity 300 mCi/mmol) was added to 100 ml buffer. The intracellular specific activities of the added amino acids were determined after tissue homogenization by automatic amino acid analysis.¹¹ By the addition of 100

*Departments of Biochemistry and Orthopaedic Surgery, University of Louvain, Belgium.

**Department of Electrotechnique, University of Louvain, Belgium. Reprint requests to W. De Loecker, M.D., Afdeling Biochemie, Campus Gasthuisberg, Herestraat. B-3000 Leuven, Belgium. Received: February 22, 1982.

μCi of $[6\text{-}^3\text{H}]$ thymidine (specific activity, 8 Ci/mmol) to 100 ml of buffer, the incorporation into DNA was measured, while with 40 μCi of $\alpha\text{-}[1\text{-}^{14}\text{C}]$ aminoisobutyric acid (specific activity, 60 mCi/mmol) the amino acid transport through the cell membrane was estimated. In a series of experiments, the possible effects of negative protein balance were avoided by adding to the incubation medium 4 ml of an L-amino acid-glucose mixture/100 ml Krebs-Ringer bicarbonate buffer (Vamin-glucose, Vitrum, Stockholm).¹²

To detect a possible latent effect of electrical stimulation, an initial electrical stimulation for 30-240 minutes in buffer without radioactive precursors present was followed by a subsequent incubation during two hours at 37 °C in fresh Krebs-Ringer bicarbonate buffer containing the appropriate tracers. This second incubation occurred without any accompanying electrical treatment. The control samples did not receive any electricity, but otherwise were treated identically.

After incubation, the skin samples were cut in portions of 200 mg and prepared for liquid scintillation counting as previously described.¹⁰ The radioactivity incorporated into the proteins and into DNA, or taken up by the cells, was expressed as disintegrations per minute (dpm).

Adenosine-5'-triphosphate (ATP) concentrations in controls and electrostimulated skin samples were assayed after incubation. The tissue (200 mg) was submerged in liquid nitrogen and in a deep cooled steel mortar at $-196\text{ }^\circ\text{C}$, reduced to a fine powder with the addition of 0.2 ml of 0.9 M perchloric acid (HClO_4 , Merck). After the further addition of 1.8 ml of HClO_4 , ATP extraction took place overnight at 2 °C. After centrifugation for 20 minutes at 12,000 g, the precipitate was again washed with 2 ml of 0.2 M HClO_4 , and the supernatants were combined. The pH was adjusted with 2 M KOH to 6.8-7.4 and the KClO_4 precipitate removed. After dilution with Tris-EDTA buffer (0.1 M pH 7.75) the ATP concentrations were measured by the luciferin-luciferase reaction (LKB, Wallac, Luminometer 1250).²⁹ Standard errors of the mean and p values, employing Student's *t*-test, were calculated.

RESULTS

On dry rat skin, the electrical resistance was established by the four-point measurement technique.³⁶ Its value, R_s , was high and decreased linearly with the applied current up to 50 μA (Fig. 2A). At higher currents the resistance levelled off, to the point at which tissue destruction occurred. The electrical resistance of skin submerged in buffer was considerably reduced, as only a fraction of the applied current passed through the tissue. Indeed, the total electrical resistance between the two electrodes was modelled by a combination of four resistances, twice the electrode-skin resistance, which was by far the largest, and the parallel combination of the resistances of the skin (R_s) and the buffer (R_B) (Fig. 3). The electrode-skin resistances were mainly the result of

polarization of the electrode-skin interfaces. The values of the resistances R_B and R_S could be separated from the electrode-skin resistances by the four-point technique (Fig. 2A). At low currents, the current through the skin was about one-sixth of that through the buffer (Fig. 2B). At currents exceeding 50 μA , however, the currents through the skin were limited to about 6 μA , whereas the current through R_B kept rising as a function of the applied currents.

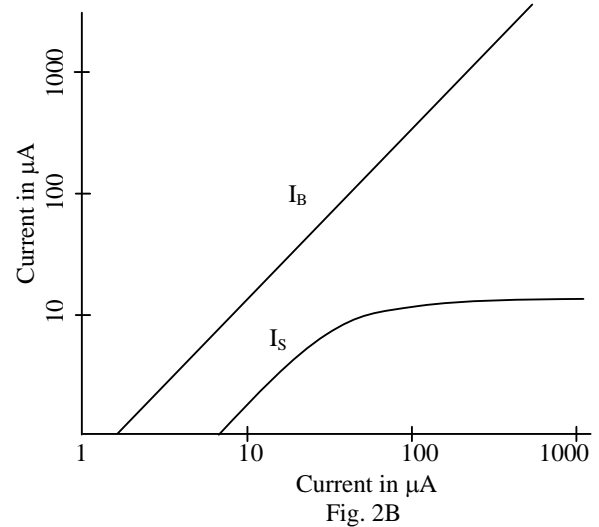
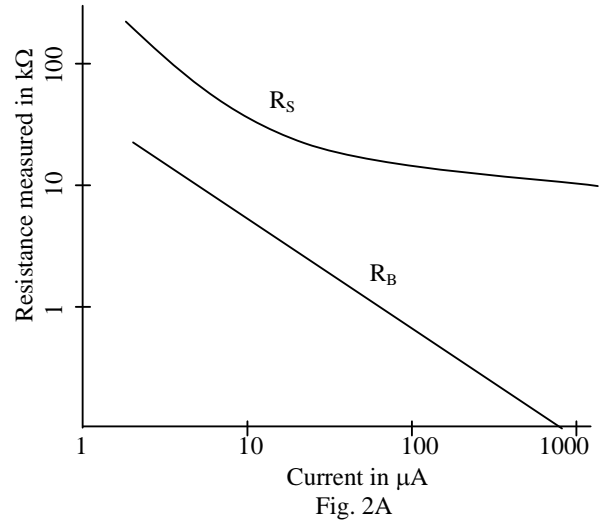

Figs. 2A and 2B. (A) The resistance of dry skin (R_S) and skin submerged (R_B) in Krebs-Ringer bicarbonate buffer, as a function of direct current, is measured by the four-point technique. (B) Currents through dry skin (I_S) and submerged skin (I_B) as a function of total applied current.

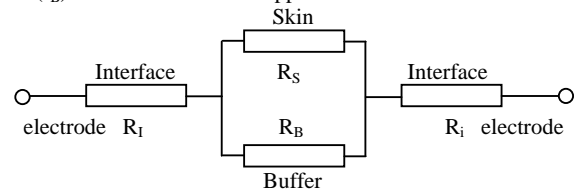

Fig. 3. Electrical model of existing resistances between the electrodes the R_1 and R_1 are equal and represent the resistances of the interface between electrode and buffer medium containing the skin. R_S and R_B are the individual resistances of the skin and buffer medium (R_1 and $R_1 \gg R_B$), respectively.

During incubation, the intracellular specific radioactivity in the total free glycine pool determined after amino acid analysis of the homogenized tissue amounted to 0.035 $\mu\text{Ci}/\mu\text{mol}$.¹¹ The $[2-^{14}\text{C}]$ glycine incorporation into the skin proteins was significantly stimulated by a constant electric current varying from 10 μA to 1000 μA . The highest stimulatory effects were obtained with 50 μA to 1000 μA , with glycine incorporation increased by as much as 75% compared

with nontreated controls. Higher current intensities, exceeding 1000 μA , inhibited the protein synthesis by as much as 50% with currents of 15,000 μA . An analogous pattern was obtained when the α - $[1-^{14}\text{C}]$ aminoisobutyric acid uptake through the cell membrane was examined. Constant currents from 100 μA to 500 μA increased the transported amino acid analog by 30%-40% above control levels. Stimulation with higher intensities reduced the α -aminoisobutyric acid uptake.

TABLE 1. Effect of Electric Current on the $[2-^{14}\text{C}]$ Glycine Incorporation into the Proteins and on the α - $[1-^{14}\text{C}]$ Aminoisobutyric Acid Uptake by the Skin

Electric Current Applied in μA	$[2-^{14}\text{C}]$ Glycine Incorporation DPM/200 mg Tissue		α - $[1-^{14}\text{C}]$ Aminoisobutyric Acid Uptake DPM/200 mg Tissue	
	Controls	Treated	Controls	Treated
1×10^{-2}	5821.7 \pm 211.4	5917.2 \pm 241.6		
1×10^{-1}	5972.6 \pm 232.4	5729.1 \pm 224.3		
1	5713.3 \pm 243.1	6329.3 \pm 244.0		
1×10	5828.0 \pm 261.2	8146.6 \pm 310.7	16789.3 \pm 964.5	17376.0 \pm 877.6
	P < 0.001			
2.5×10	6000.0 \pm 254.6	7246.6 \pm 267.7	17820.5 \pm 745.9	19780.2 \pm 911.6
	P < 0.01			
5×10	5637.3 \pm 236.2	8157.3 \pm 324.6	17641.3 \pm 824.9	17318.6 \pm 754.2
	P < 0.001		P < 0.001	
1×10^2	6078.6 \pm 248.6	9917.3 \pm 377.2	19036.1 \pm 767.4	27270.6 \pm 1274.8
	P < 0.001		P < 0.001	
2.5×10^2	6257.1 \pm 272.4	10385.0 \pm 367.9	18616.3 \pm 897.0	24205.3 \pm 1149.5
	P < 0.001		P < 0.01	
5×10^2	5348.0 \pm 189.9	9360.0 \pm 267.9	18242.6 \pm 979.4	25940.2 \pm 1381.0
	P < 0.001		P < 0.01	
7.5×10^2	5356.1 \pm 234.6	9106.6 \pm 298.0	19161.1 \pm 1067.5	23357.3 \pm 1296.7
	P < 0.001			
1×10^3	5740.2 \pm 208.6	8609.3 \pm 267.6	17166.6 \pm 864.9	18066.6 \pm 941.1
	P < 0.001			
5×10^3	5874.6 \pm 174.9	5962.6 \pm 208.6	19764.1 \pm 1090.6	15818.6 \pm 821.3
1×10^4	6148.1 \pm 237.9	5200.5 \pm 213.7	18642.6 \pm 825.8	13664.5 \pm 761.0
			P < 0.001	
1.5×10^4	6526.6 \pm 262.1	3296.0 \pm 154.6		
	P < 0.001			
3×10^4	6301.3 \pm 286.1	3289.3 \pm 154.9	16961.3 \pm 822.1	3357.3 \pm 315.8
	P < 0.001		P < 0.001	

Rat skin tissue flaps, measuring 5 x 6 cm, clamped between two adjustable electrodes were incubated for 2 hrs at 37 ° C in 100 ml of Krebs-Ringer bicarbonate buffer, pH 7.4, containing either 40 μCi of $[2-^{14}\text{C}]$ glycine or 40 μCi of α - $[1-^{14}\text{C}]$ aminoisobutyric acid, as well as the usual antibiotics. Treatment with different constant electric currents varying from 1×10^{-2} μA to 3×10^4 μA was carried out during the incubation period, and the results were compared with those of controls not receiving any electric treatment. Subsequently, the incorporated radioactivity in 200 mg tissue was counted. Each value represents the mean of 8 experiments \pm SEM. p values between controls and treated samples are given where significant.

With currents of 10,000 μA and of 30,000 μA , the α -aminoisobutyric acid uptake was reduced to 73% and 20%, respectively, of the control values (Table 1).

After the addition to the incubation medium of a mixture of L-amino acids, the absolute glycine incorporation values and α -aminoisobutyric acid uptake increased. The electrostimulation had resulted in a stimulatory effect even more pronounced than that observed in buffer without amino acid supplement.

Treatment with 100 μA increased the glycine incorporation by 72% (p < 0.001) and the α -aminoisobutyric acid uptake by 41% (p < 0.001) above the nontreated control values. Electrostimulation with 500 μA increased the glycine incorporation by 123% (p < 0.001) and the α -aminoisobutyric acid uptake by 90% (p < 0.001) (Table 2). Because electrical treatment during incubation with $[2-^{14}\text{C}]$ glycine was prolonged, the stimulatory effects observed with 500 μA became

progressively more pronounced, amounting to 85% above control levels after an incubation period of four hours (Table 3). The effects of electrical treatment in skin incubated in Krebs-Ringer bicarbonate buffer containing other amino acids, *e.g.*, L-[U-¹⁴C]isoleucine or L-[U-¹⁴C]alanine, were analogous to those observed after incubation with [2-¹⁴C]glycine. The stimulatory effects of electric currents on the protein synthesizing

activity began at 10 μ A, while the α -aminoisobutyric acid uptake only became evident after treatment with 100 μ A. With increasing electric currents, the inhibitory effect on α -aminoisobutyric acid appeared at 750 μ A, while glycine incorporation was still stimulated after treatment with 1000 μ A (Fig. 4). These results were identical during static incubation or after constant shaking of the medium.

TABLE 2. Effect of Electric Current on the [2-¹⁴C]Glycine Incorporation into the Proteins and on the α -[¹⁴C]Aminoisobutyric Acid Uptake by Skin During Incubation in an Amino-Acid Containing Medium

Electric Current Applied μ A	[2- ¹⁴ C] Glycine Incorporation DPM/200 mg Tissue		α -[¹⁴ C] Aminoisobutyric Acid Uptake DPM/200 mg Tissue	
	Controls	Treated	Controls	Treated
100	7200 \pm 510	12400 \pm 840	20895 \pm 1050	29549 \pm 1840
500	7520 \pm 570	16810 \pm 1050	21040 \pm 1124	39974 \pm 2080

The skin was essentially treated as outlined in Table 1. The Krebs-Ringer bicarbonate buffer, however, contained 2.2 mM glucose and a supplement of the following L-amino acids expressed as μ mol/100 ml buffer: alanine, 134.4; arginine, 75.6; aspartic acid, 123.2; cysteine/cystine, 32.8; glutamic acid, 244.4; glycine, 111.6; histidine, 61.6; isoleucine, 118.8; leucine, 161.2; lysine, 100.2; methionine, 50.8; phenylalanine, 132.8; proline, 281.2; serine, 285.2; threonine, 100.4; tryptophan, 19.2; tyrosine, 10.8; valine, 146.4. Each value is the mean of eight experiments \pm SEM.

The [6-³H]thymidine incorporation into DNA of skin tissue was not affected by treatment with various constant electric currents.

To detect a possible latent effect of electrical stimulation, skin tissue was treated with direct currents varying from 1 μ A to 1 \times 10⁴ μ A in Krebs-Ringer bicarbonate buffer for up to 240 minutes without labelled precursors present. This initial incubation was followed by a second incubation without any electrical treatment for one or two hours in buffer containing either [2-¹⁴C]glycine, α -[¹⁴C]aminoisobutyric acid, or

[6-³H]thymidine. The uptake of radioactive tracers was never affected by any previous electrical treatment, eliminating the possibility of a latent effect.

The electrical stimulation of protein synthesizing activity and of amino acid transport through the cell membrane only occurred when the skin was attached to both electrodes. Skin tissue flaps attached to one electrode only, with the other end freely floating in the buffer toward the second electrode, were not affected by electrical stimulation. (Table 4).

TABLE 3. The Effect of Time of Treatment by Electric Current on the [2-¹⁴C]Glycine Incorporation in the Proteins of Rat Skin

Time of Treatment (min)	[2- ¹⁴ C]Glycine Incorporation. DPM/200 mg Tissue	
	Controls	Skin Treated with 500 μ A
30	2674.5 \pm 135.6	3265.5 \pm 156.7
60	3924.6 \pm 162.7	6098.8 \pm 276.8
		P < 0.001
120	5862.0 \pm 364.0	9965.4 \pm 476.2
		P < 0.001
180	7245.6 \pm 564.2	13013.0 \pm 771.7
		P < 0.001
240	8224.3 \pm 662.1	15288.9 \pm 832.3
		P < 0.001

Skin tissue treated as outlined in Table 1 was incubated for different durations varying from 30 to 240 min, in 100 ml Krebs-Ringer bicarbonate buffer, pH 7.4, containing, apart from the usual antibiotics, 40 μ Ci[2-¹⁴C]glycine. The incorporated radioactivity in samples treated with a constant electric current of 500 μ A was compared with nontreated controls. Each value represents the mean of 8 experiments \pm SEM; p values between controls and treated samples are given.

Electrostimulation of the tissue resulted in remarkably increased ATP concentrations. With currents from 50 μ A to 1000 μ A, the ATP levels were increased threefold to fivefold. With currents from 100 μ A to 500 μ A, the stimulatory effects were similar. With currents exceeding 1000 μ A, the ATP concentration levelled, and with 5000 μ A, they were even reduced slightly as compared with the nontreated controls (Table 5).

Fig. 4. Effect of electric current treatment on glycine incorporation and on α -aminoisobutyric acid uptake. The stimulatory and inhibitory effects of different DC currents on the incorporation of [2- 14 C]glycine (●) into the proteins and on the cellular uptake of α -[14 C]aminoisobutyric acid (○) are expressed as percentages of the control incorporation values of skin not submitted to electrical treatment. Each value represented is the mean of 8 experiments \pm SEM.

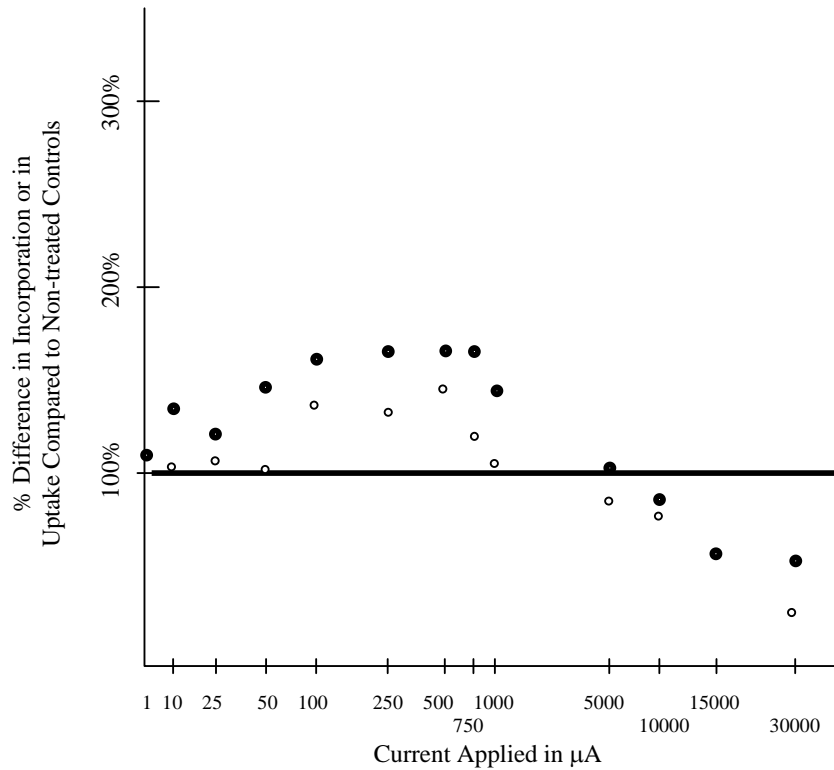

TABLE 4. Effect of DC Current on Skin Attached to One or Two Electrodes

Treatment with 500 μ A DC Current for 2 hours	[2- 14 C]Glycine Incorporation. (DPM/200 mg Tissue)	α -[14 C]Aminoisobutyric Acid Uptake (DPM/200 mg Tissue)
Skin attached to two electrodes	14485 \pm 759	33719 \pm 1864
Skin attached to one electrode	7994 \pm 877	17894 \pm 1052

The skin, essentially treated as outlined in Table 1, either was attached to both electrodes or only attached to one electrode, incubation occurred for 2 hours at 37 $^{\circ}$ C with DC stimulation of 500 μ A. The incorporation or uptake values are expressed as disintegration/min (mean of 8 experiments \pm SEM).

Table 5. The effects of Electrostimulation on the ATP Concentrations in Rat Skin.

Electrical Treatment Current μ A	ATP Concentration (μ mol/gm Tissue)
Controls (Without)	4.2 \pm 0.8
10	10.0 \pm 1.5
50	14.2 \pm 1.2
100	16.9 \pm 1.9
500	20.1 \pm 2.2
1000	15.0 \pm 1.8
5000	3.9 \pm 0.6

After incubation in amino acid containing buffer for 2 hours without or with electrostimulation, 200 mg tissue was reduced to powder at -196 $^{\circ}$ C with 0.2 ml of 0.9 M perchloric acid, followed by a further addition of 1.8 ml of HClO₄. ATP Extraction was carried out overnight at 2 $^{\circ}$ C (Materials and Methods). ATP concentrations were assayed by the luciferin-luciferase reaction. Each value represents the mean of eight experiments \pm SEM.

DISCUSSION

Minimum current intensities of approximately 50 μ A are necessary to obtain a maximal stimulatory effect on protein synthesis. When higher currents are applied,

the current passing through the skin does not increase significantly. These stimulatory effects are maintained to a level of approximately 1000 μ A. The application of

a specific current implies that only a small fraction is responsible for the metabolic effects. This is particularly noticeable with skin that is attached on one side only to an electrode, with the other end floating freely in the buffer. In this system the skin is not affected by the electric currents, which obviously only pass through the buffer from one electrode to the other. Possible electrolytic effects are negligible with the smaller currents. Only when high currents, above 1000 μA , are applied, may electrolysis adversely affect metabolism. Although electrolysis depends on the voltage changes, it is not expected to occur in this system, because the voltages measured at the interfaces never exceed 1.5 V with the platinum and stainless steel electrodes. Constant shaking of the medium or static incubation of the skin does not affect the metabolic results, indicating that interference by accumulated electrolyte products is not probable.

When the relatively low amino acid incorporation values are considered in function of the intracellular specific radioactivity, the glycine incorporation becomes even more significant, thereby proving this skin system a viable preparation.^{10,12} The stimulatory effect of direct current on amino acid incorporation into proteins precedes and exceeds the effects on amino acid transport as expressed by the α -[^{14}C]aminoisobutyric acid uptake. This metabolically inactive amino acid analog is actively concentrated in the cells and transported through the membranes by the same carrier as glycine.^{15,32} With higher currents the inhibitory effects are first observed on amino acid transport, which is more drastically affected than protein synthesis. Electrostimulation seems to increase protein synthesizing activity primarily and independently, although subsequent stimulation of amino acid transport results in an additional increase in the amino acid incorporation into the proteins. Inasmuch as these effects only occur during the application of the current, without any latent effects, electrical stimulation directly affects protein metabolism, which even receives an additional impulse from the increased availability of free amino acids. The addition of a supplement of amino acids to the incubation buffer accentuates the stimulatory effects of electric current on metabolism.

DNA metabolism is not affected by electrical stimulation, suggesting that the stimulatory and inhibitory effects on protein synthesizing activity occur independently of an effect on transcriptional processes. The metabolic stimulation persists as long as the tissue remains viable. When incubation is prolonged, the incorporation values level, indicating structural damage to the tissue.⁴⁰ Electrical treatment has been observed to stimulate *in vitro* growth of the epiphyseal plate of rats, as well as protein synthesis in mature nucleated frog erythrocytes without affecting DNA metabolism.^{3,5,6,20,21}

An increased ATP generation also occurs in chloroplasts subjected to an artificial electrical potential difference induced by an external electric field.⁴¹ An artificial proton gradient across the functional membrane, created by acid-base transitions, result in ATP formation in chloroplasts.²³ These results support the chemiosmotic theory of Mitchell.^{30,31} The

stimulatory effects of electric current on ATP formation in skin tissue also can be explained by this principle; During electrostimulation, the electrons react with water molecules at the cathodic side to produce hydroxyl ions, while at the anodic side, protons are formed. Thus, between the anodic and cathodic interface, a proton gradient and a potential gradient across the tissue and the medium are created. Hence, protons under influence of the electric field and the concentration difference should move from anode to cathode. Since the rate of production formation at the anodic interface is equal to the rate of proton consumption at the cathodic interface, the net pH of the system, medium and tissue, remains undisturbed. As the migrating protons reach the mitochondrial membrane-bound H^+ -ATPase, ATP will be formed.^{30,31} Substrate oxidation, which is accompanied by proton migration across the membranes, may equally be stimulated by the electrically induced proton current, acting in a feedback manner. This view, however, does not exclude the contribution of other factors or, possibly, specific receptor systems to the final effects. A latent effect of current treatment never has been observed. As on interruption of the current, the proton movement ceases and the reversible ATPase system is able to restore equilibrium. Insofar as protein synthesis depends on adequate ATP levels, the increased ATP production is partially responsible for the increased protein synthesis.^{24,25} Another factor resulting in the increased protein synthesis is the amino acid availability, which is equally increased due to the stimulated amino acid transport. The electrical effects on amino acid transport through the cell membranes also may be mediated by changes in transmural potential differences modifying ionic fluxes and transport.^{22,33} Although protein synthesis and amino acid transport are both stimulated, the mechanisms of action by which electric current exerts its effects differ.

SUMMARY

Direct electric currents ranging from 10 μA to 1000 μA increase ATP concentrations in the tissue and stimulate amino acid incorporation into the proteins of rat skin. The amino acid transport through the cell membrane, followed by the α -aminoisobutyric acid uptake, is stimulated between 100 μA and 750 μA . The stimulatory effects on ATP production and on amino acid transport, apparently mediated by different mechanisms, contribute to the final increased protein synthesizing activity, DNA metabolism followed by thymidine incorporation remains unaffected during the course of current application. The effects on ATP production can be explained by proton movements on the basis of the chemiosmotic theory of Mitchell, while the transport functions are controlled by modifications in the electrical gradients across the membranes.

ACKNOWLEDGMENT

The authors are indebted to the Belgian National Foundation for Medical Research (F.G.W.O.) for a grant to the laboratory.

REFERENCES

1. Assimacopoulos, D.: Wound healing promotion by the use of negative electric current, *Am. J. Surg.* 34:423, 1968.
2. Basset, C. A. L.: Biological significance of piezoelectricity. A review. *Calcif. Tissue Res.* 1:252, 1968.
3. Basset, C. A. L.: The effect of electrostatic fields on macromolecular synthesis by fibroblasts *in vitro*. *J. Cell. Biol.* 39:9a, 1968.
4. Basset, C. A. L., Pawluk, R. J., and Pills, A. A.: Augmentation of bone repair by inductively coupled electromagnetic fields. *Science* 184:575, 1974.
5. Bozoky, L., Kiszely, G., Hoffman, T. A., and Ladik, J.: Effect of electrostatic fields on cell mitosis. *Nature* 199:1306, 1963.
6. Brighton, C. T., Cronkey, J. E., and Osterman, A. L.: *In vitro* epiphyseal-plate growth in various constant electrical fields, *J. Bone Joint Surg.* 58A:971, 1976.
7. Brighton, C. T., Friedenburg, Z. B., Mitchell, E. I., and Booth, R. E.: Treatment of non-union with constant direct current. *Clin. Orthop.* 124:106, 1977.
8. Brighton, C. T., Friedenburg, Z. B., Zernsky, L. M., and Pollis, P. R.: Direct current stimulation of non-union and congenital pseudarthrosis. *J. Bone Joint Surg.* 57A:368, 1975.
9. Constable, J. D., Scupicchio, A. P., and Opitz, B.: Studies of the effects of diapulse treatment of various aspects of wound healing in experimental animals. *J. Surg. Res.* 11:254, 1971.
10. De Loecker, W., De Wever, F., Jullet, R., and Stas, M. L.: Metabolic changes in rat skin during preservation and storage in glycerol buffer at -196°C . *Cryobiology* 13:24, 1976.
11. De Loecker, W., and Stas, M. L.: Effect of cortisol treatment on free amino acid level in rats. *J. Endocrinol.* 59:57, 1973.
12. De Loecker, W., De Wever, F., Jullet, R., and Stas, M. L.: The effects of cortisol and amino acids on the metabolic activity of rat skin stored in dimethylsulfoxide buffer at -196°C . *Cryobiology* 15:59, 1978.
13. Erikson, C.: Streaming potentials and other water dependant effects in mineralized tissues. *Ann. N.Y. Acad. Sci.* 238:321, 1974.
14. Erikson, C.: Electrical properties of bone. *In* Bourne, G. H. (ed.): *Biochemistry and Physiology of Bone*. Vol. 4. New York, Academic Press, 1976, pp. 329-384.
15. Florey, W., and Neuhaus, O. W.: Induced transport of amino acids in rat liver after wholebody γ irradiation. *Radiat. Res.* 68:138, 1976.
16. Friedenberg, Z. B., Harlow, M. C., and Brighton, C. T.: Healing of non-union of the medial malleolus by means of direct current. A case report. *Trauma* 11:883, 1971.
17. Fukada, E.: Piezoelectric properties of organic polymers. *Ann. N.Y. Acad. Sci.* 238:7, 1974.
18. Fukada, E., and Yasuda, I.: On the piezoelectric effect of bone. *J. Phys. Soc. Jpn.* 12:1158, 1957.
19. Gensler, W.: Bioelectric potentials and their relation to growth in higher plants. *Ann. N.Y. Acad. Sci.* 238:280, 1974.
20. Harrington, D. B., and Becker, R. O.: Electrical stimulation of RNA and protein synthesis in the frog erythrocyte. *Exp. Cell. Res.* 76:95, 1973.
21. Harrington, D. B., Meyer, R., and Klein, R. M.: Effects of small amounts of electric current at the cellular level. *Ann. N.Y. Acad. Sci.* 238:300, 1974.
22. Hubel, K. A.: The effects of electrical field stimulation and tetrodotoxin on ion transport by isolated rabbit ileum. *J. Clin. Invest.* 62:1039, 1977.
23. Jagendorf, A. T., and Uribe, E.: ATP formation caused by acid base transition of spinach chloroplasts. *Proc. Natl. Acad. Sci. U.S.A.* 55:170, 1966.
24. Kaziro, Y.: The role of guanosine-5'-triphosphate in polypeptide chain elongation. *Biochim. Biophys. Acta.* 505:95, 1978.
25. Keller, F. B., and Zamecnik, P. D.: The effects of guanosine diphosphate and triphosphate on the incorporation of labeled amino acids into proteins. *J. Biol. Chem.* 221:45, 1956.
26. Korostoff, E.: Stress generated potentials in bone: Relationship to piezoelectricity of collagen. *J. Biomech.* 10:41, 1977.
27. Lanyon, L. E., and Hartman, W.: Strain related electrical potentials recorded *in vitro* and *in vivo*. *Calcif. Tissue Res.* 22:315, 1977.
28. Lavine, L. S., Lustrin, I., and Shamos, M. H.: Treatment of congenital pseudarthrosis of the tibia with direct current. *Clin. Orthop.* 124:69, 1977.
29. Lundin, A., and Thore, A.: Analytical information obtainable by evaluation of the time course of firefly bioluminescence in the assay of ATP. *Anal. Biochem.* 66:47, 1975.
30. Mitchell, P.: Chemiosmotic coupling in oxidative and photosynthetic phosphorylation. *Biol. Rev.* 41:445, 1966.
31. Mitchell, P.: Vectorial chemistry and the molecular mechanism of chemiosmotic coupling: Power transmission by proticity. *Biochem. Soc. Trans.* 4:400, 1976.
32. Oxender, D. L., and Christensen, H. N.: Distinct mediating systems for the transport of neutral amino acids by the Ehrlich cell. *J. Biol. Chem.* 238:3686, 1963.
33. Pilla, A. A., and Margules, G. S.: Dynamic interfacial electrochemical phenomena at living cell membranes: Application to the toad urinary bladder membrane system. *L. Electrochem. Soc.* 124:1697, 1977.
34. Romero-Sierra, C., and Tanner, J. A.: Biological effects of nonionizing radiation: An outline of fundamental laws. *Ann. N.Y. Acad. Sci.* 238:263, 1974.
35. Rowley, B. A., McKenna, J. M., Chase, G. R., and Wolcott, L. E.: The influence of electrical current on an infecting microorganism in wounds. *Ann. N.Y. Acad. Sci.* 238:543, 1974.

36. Sansen, W., and De Dijcker, F.: The four point probe technique to measure bio-impedances. *Electromyogr. Clin. Neurophysiol.* 16:509, 1976.
37. Shamos, M. H., and Lavine, L. S.: Piezoelectricity as a fundamental property of biological tissues. *Nature.* 213:267, 1967.
38. Spadaro, J. A.: Electrically stimulated bone growth in animals and man. Review of the literature. *Clin. Orthop.* 122:325, 1977.
39. Stan, S., Mulier, J. C., Sansen, W., and Dewaele, P.: Effect of direct current on the healing of fractures. *In* Burney, F., Herbst, E., and Hinsenkamp, M. (eds.): *Electric Stimulation of Bone Growth and Repair*, Berlin, Heidelberg, New York, Springer-Verlag, 1978, pp. 47-53.
40. Van der Schueren, B., Doms, D., and De Loecker, W.: Storage damage in ratskin preserved at -3°C . *Cryobiology.* 11:526, 1974.
41. Witt, H. T., Schlodder, E., and Graber, P.: Membrane-bound ATP synthesis generated by an external electric field. *FEBS Lett.* 69:272, 1976.
42. Wolcott, L. E., Wheeler, P. C., Hardwicke, H. M., and Rowley, B.: Accelerated healing of skin ulcers by electrotherapy: Preliminary clinical results. *South. Med. J.* 62:795, 1969.
43. Wu, K. T., Go, N., Dennis, C., Enquist, I., and Sawyer, P. N.: Effects of electric currents and interfacial potentials on wound healing. *J. Surg. Res.* 7:122, 1967.

Retyped from:
Clinical Orthopaedics
and
Related Research
Number 171
November-December, 1982.
Pages 264 to 272

