

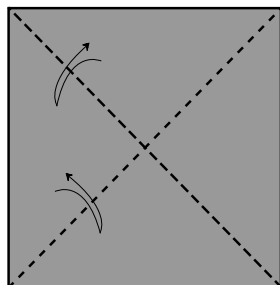

# A Cup of "..."

Design and diagram © by Silas Vriend

This cup arose out of the simple desire to make a cup full of liquid, after seeing a styrofoam cup filled with coffee at a luncheon in 2008. Use a two-coloured square of tissue-foil for the best results.



1. Precrease the diagonals.

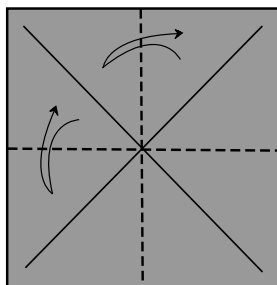

2. Precrease the horizontals.

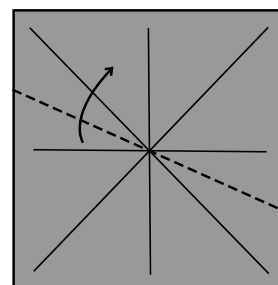

3. Fold along angle bisectors.

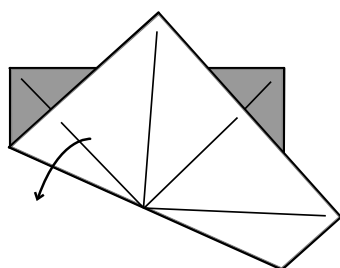

4. Note how the creases are aligned. Unfold.

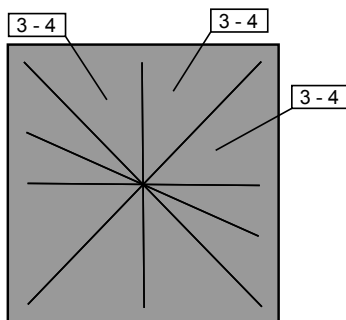

5. Repeat Steps 3-4 three times.

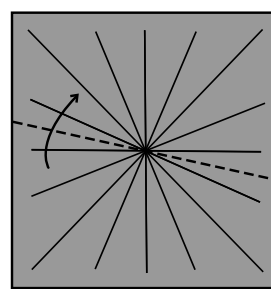

6. Fold along angle bisectors.

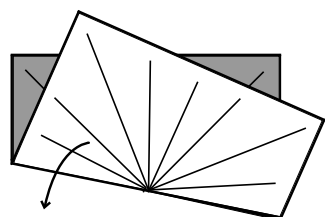

7. Note how the creases are aligned. Unfold.

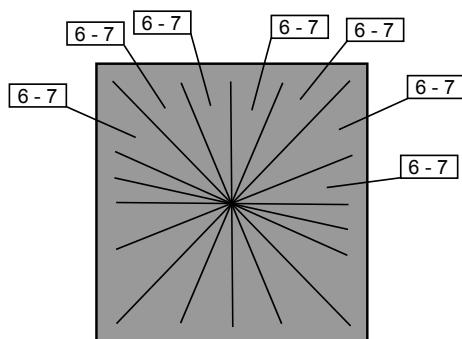

8. Repeat Steps 6-7 seven times.

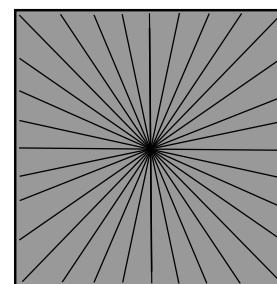

9. For the sake of clarity, the radial creases will be extended almost to the edges from here on in.

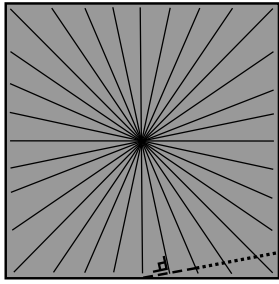

10. Precrease at a right angle, creasing only where shown.\*

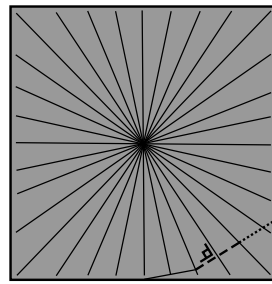

11. Precrease at a right angle, creasing only where shown.\*

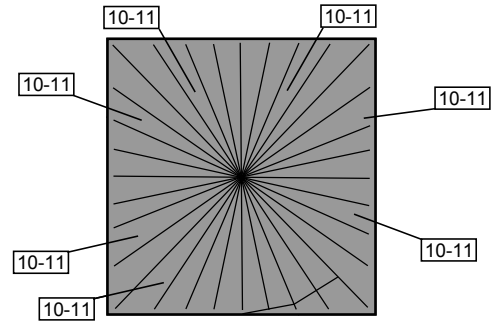

12. Repeat Steps 10-11 seven times.

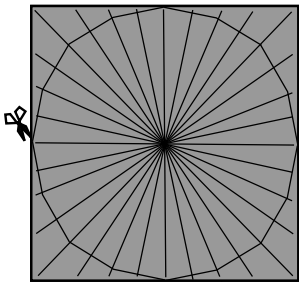

13. Cut along the creases you made in steps 10-12

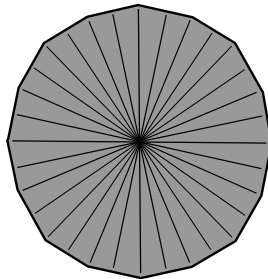

14. You have now obtained the 16-gon!

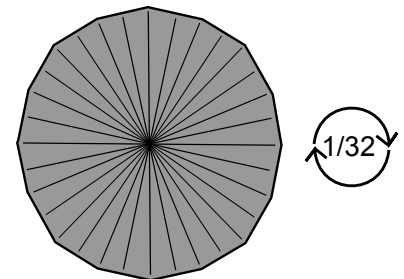

15. Rotate the 16-gon by  $1/32$

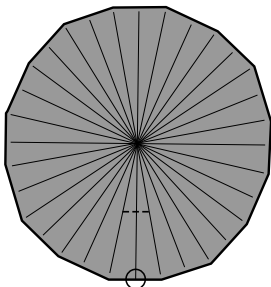

16. Fold the circled point to the center, creasing only where shown.\* Unfold.

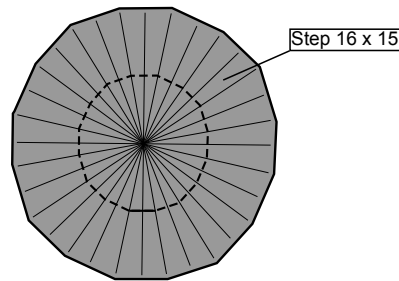

17. Repeat Step 16 fifteen times.

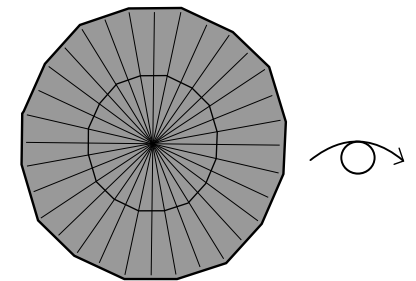

18. Flip over.

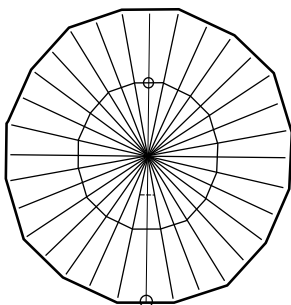

19. Fold the circled point to the other circled point, creasing only where shown.\* Unfold.

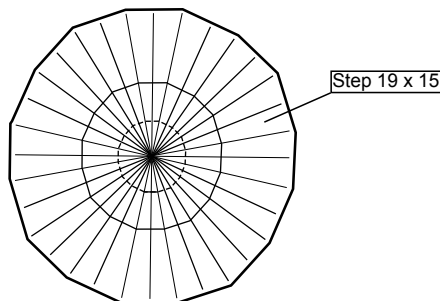

20. Repeat Step 19 fifteen times.

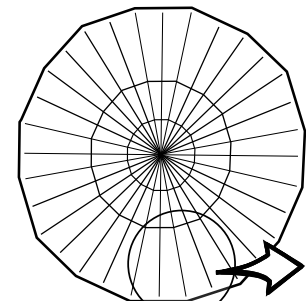

21. Zoom in on circled part.

\*An arrow has been left out here, for the sake of clarity.

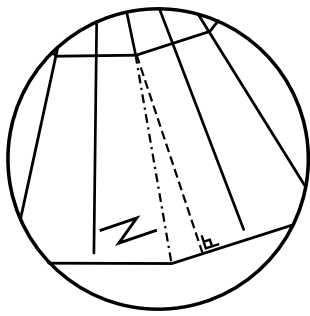

22. Crimp, at a right angle.

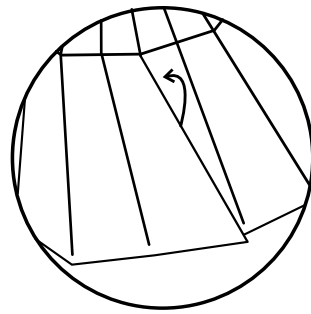

23. Unfold. Zoom out.

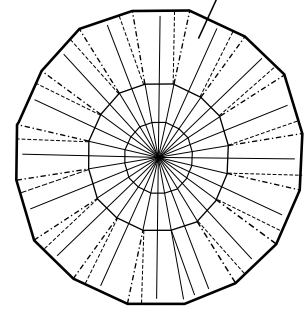

24. Repeat Steps 22-23 fifteen times.

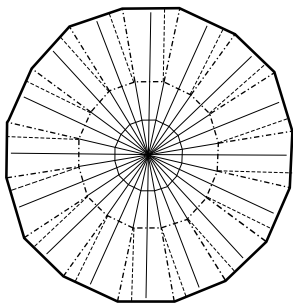

25. Collapse upon the creases that you made in steps 22-23.

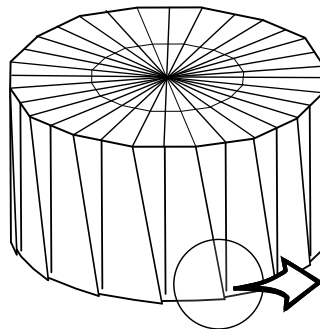

26. Zoom in.

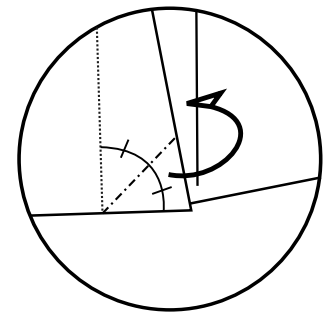

27. Lock the pleat with a mountain fold on an angle bisector.

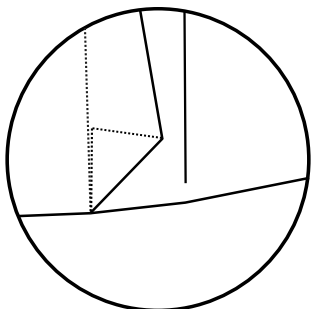

28. Zoom out.

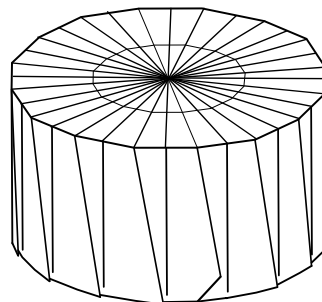

29. Repeat steps 26-28 15 times (all the way around).

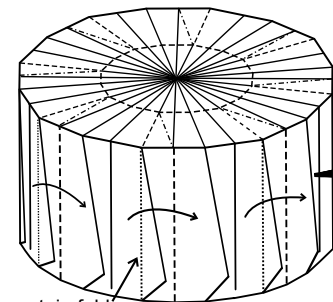

30. Make 8 pleats on existing creases, pushing down on the middle part.

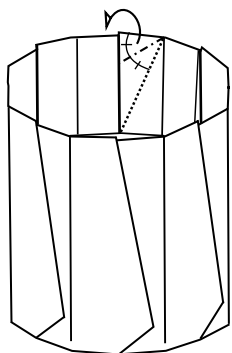

31. Mountain fold on an angle bisector to lock the pleat.

Step 31 x 7

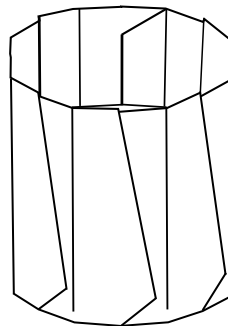

32. Repeat step 31 seven times (all the way around).

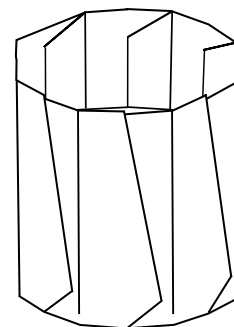

33. Flip over.

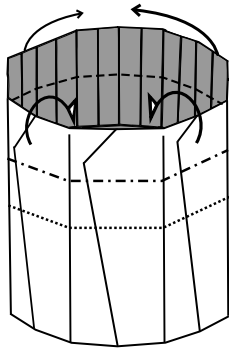

34. Mountain fold, all the way around.

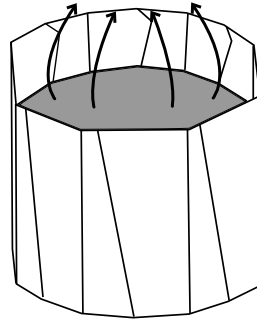

35. Apply pressure from underneath, so as to puff the "liquid" level up past the folded-in edges.

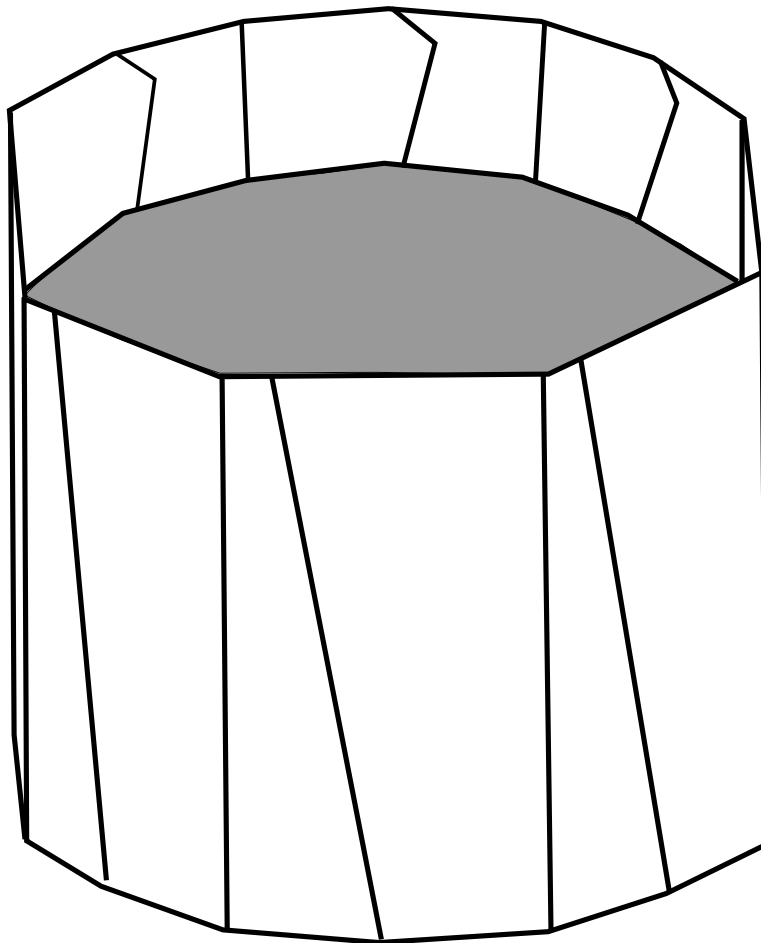

36. It's done!