

**Manatee v 1.0**  
 © Geoff Mayhew 2009  
 Page 1

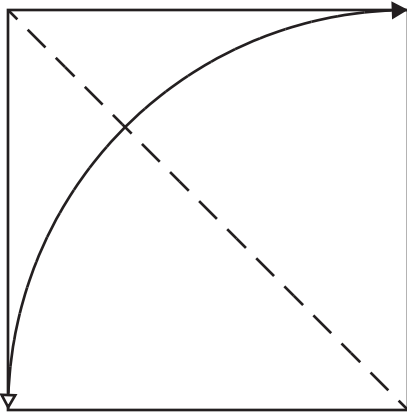

**[1]** Start white side up. Valley fold corner to corner. Unfold.

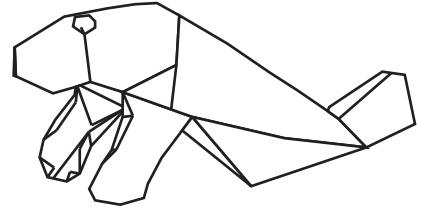
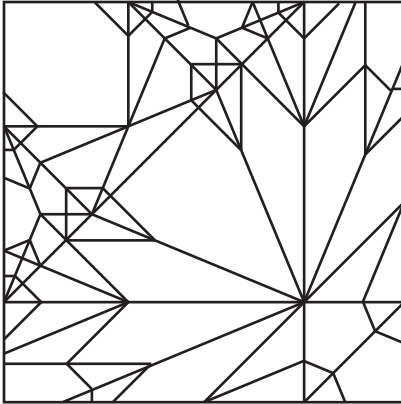
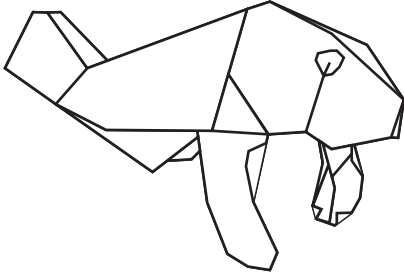
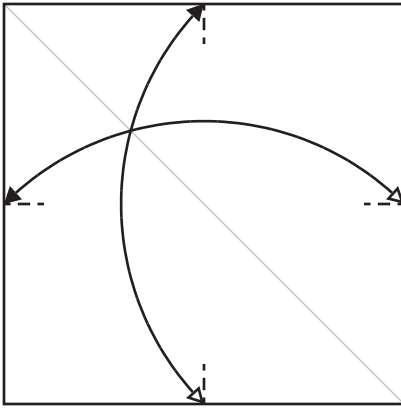

**[2]** Valley fold from edge to edge both ways, but only crease on the ends. Unfold.

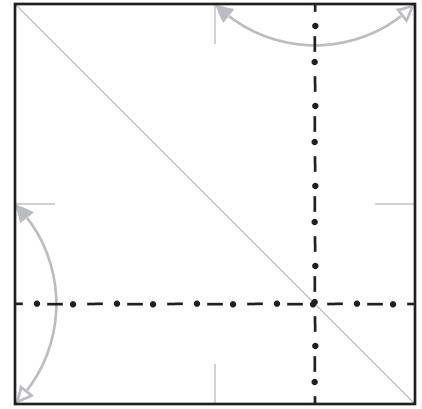

**[3]** Using the marks from the previous step, make the mountain folds as shown. Unfold.

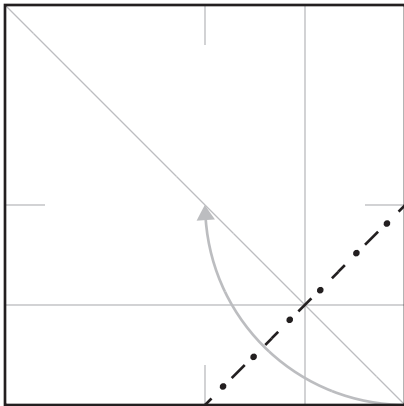

**[4]** Mountain fold diagonally using the previous creases.

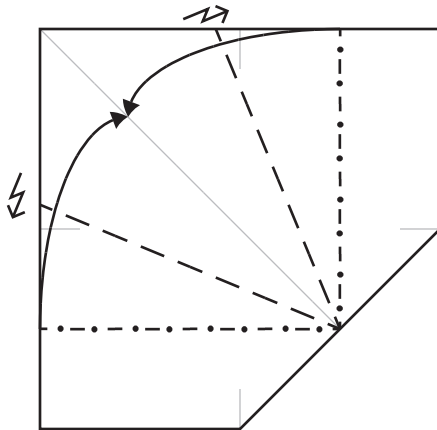

**[5]** Crimps on both sides by bisecting between precreases. The model will not lie flat.

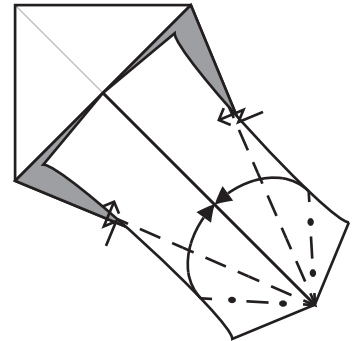

**[6]** Crimp by bisecting between precreases again. The model will lie flat now.

**Manatee v 1.0**  
 © Geoff Mayhew 2009  
 Page 2

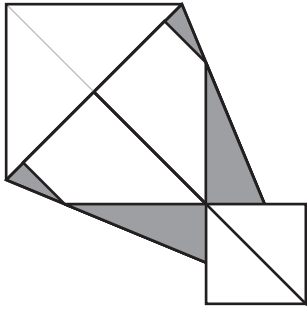

[7] This is the result. Turn the paper over.

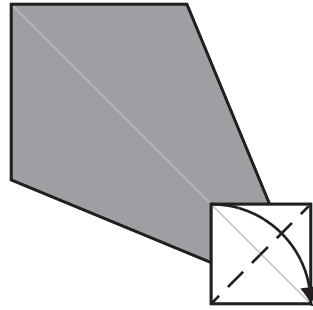

[8] Valley fold the corner down.

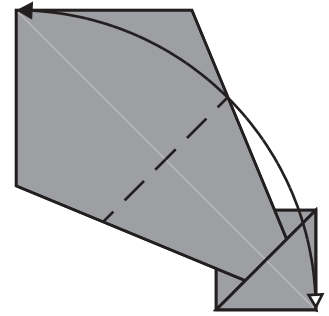

[9] Valley fold the topmost layer only, from corner to corner, then unfold.

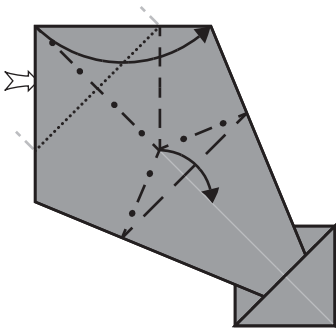

[10] Squash fold. The upper-left edges of the paper must meet the edges of the layers underneath.

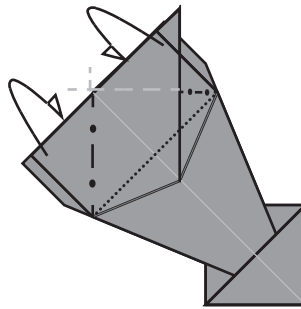

[11] Inside reverse fold two corners.

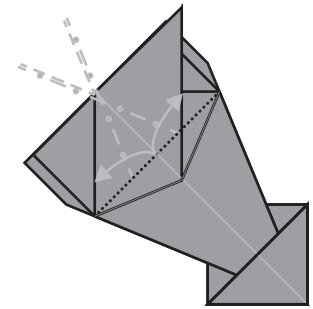

[12] Inside reverse fold again, in the opposite direction.

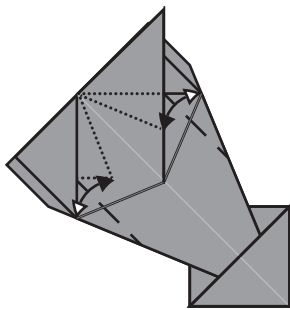

[13] Fold the outside corners in as far as they'll go. Keep the creases parallel to the center line.

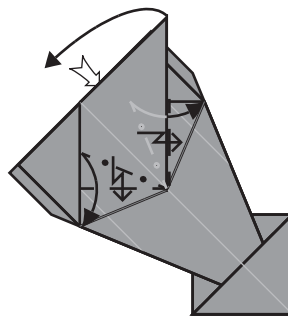

[14] Squash the corner down, pleating on both sides.

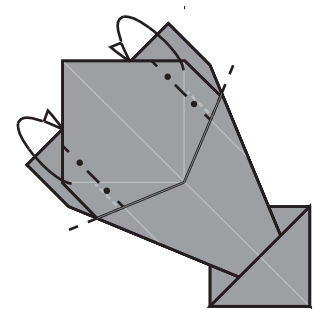

[15] Inside reverse fold, making the creases in line with the precrease.

**Manatee v 1.0**  
 © Geoff Mayhew 2009  
 Page 3

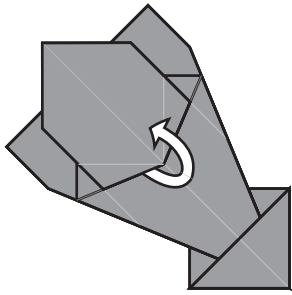

**[16]** Pull out the layer of paper from underneath, wrapping the layer above it.

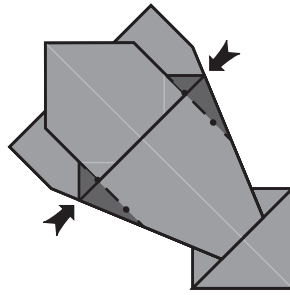

**[17]** Closed sink the two corners using the precreases from earlier.

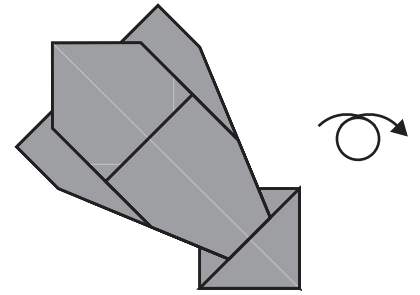

**[18]** This is the result. Turn the paper over.

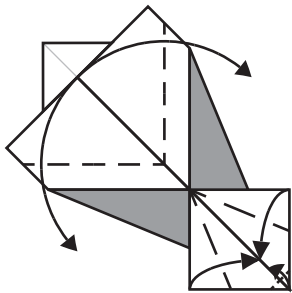

**[19]** Valley fold the fins down. Also valley fold the sides of the tail and the tip of the tail in.

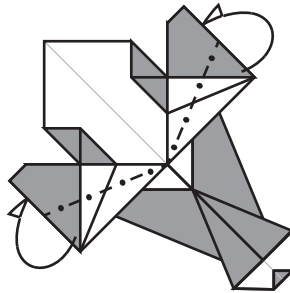

**[20]** Mountain fold inside, making the fins thinner.

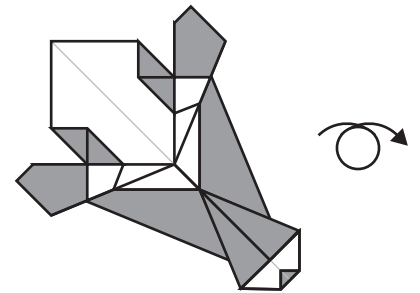

**[21]** This is the result. Turn the paper over.

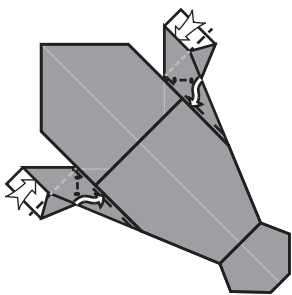

**[22]** Squash the flippers, tucking the excess paper inside of the pocket formed by the sink made in step 17.

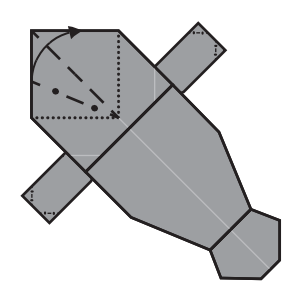

**[23]** Round the flippers with mountain folds. Round the head, using the reference points shown.

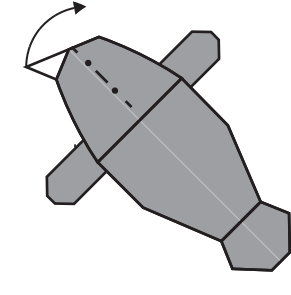

**[24]** Fold the flap under the head to the right. Then, unfold to step 23.

**Manatee v 1.0**  
© Geoff Mayhew 2009  
Page 4

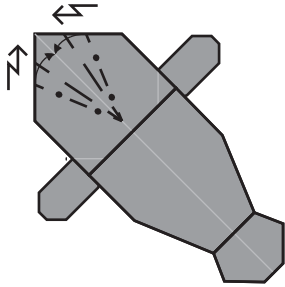

[25] Pleat towards the center line, bisecting the angle created in the previous step.

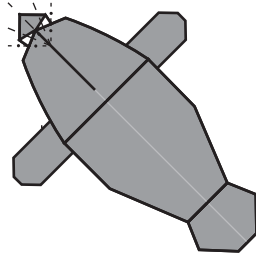

[26] Pleat again on the nose, much like before, to form the muzzle.

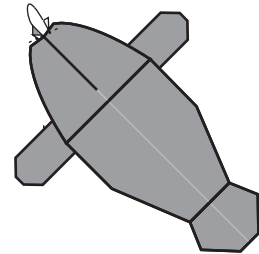

[27] Mountain fold the excess paper behind, inside the model, to lock the muzzle closed.

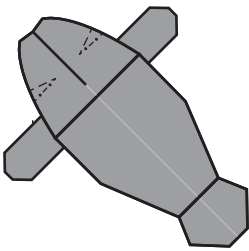

[28] Crimp both sides of the head as shown.

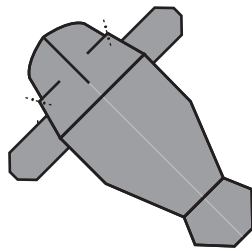

[29] Mountain fold where the crimps meet the edge to lock them in place.

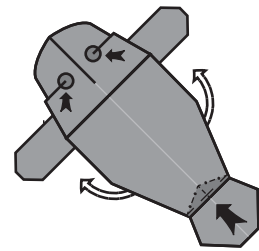

[30] Sink the tail into the body, pull out paper under the body, indent the eyes, and round the whole body.

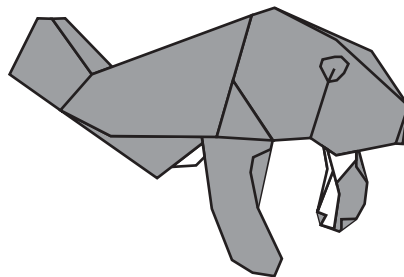

[31] Finished.