



EMC Research Institute  
 66-6, Jeil-Ri, Yangji-Myun, Cheoin-Gu  
 Yongin-Si, Gyeonggi-Do, Korea  
 Tel: +82-31-679-9600 Fax: +82-31-336-1184

# EMC TEST REPORT

Page 1 of 35

## Emission and Immunity of electromagnetic disturbance

**Test Report No.** : CEC2009-0190  
**Equipment** : CCTV Camera  
**Name of basic model** : SCC-C6455P  
**Variant model** : SCC-C6453P, SCC-C7455P, SCC-C7453P  
**Manufacturer** : Tianjin Samsung Electronics Co., Ltd.  
**Applicant** : Samsung Electronics Co., Ltd.  
**Tested date** : 2009. 06. 26 – 2009. 07. 01.  
**Receipt of date** : 2009. 06. 26.  
**Issued date** : 2009. 07. 02.  
**Tested Environment** : Temperature:(21.9 – 25.0) °C, Relative Humidity:(44.5 – 49.5) %  
 R.H., Atmospheric Pressure : (98.2 – 100.4) kPa  
**Test results** : Pass  
**Test Standards** : EN 55022 : 2006  
 EN 50130-4 : 1995 + A1 : 1998 + A2 : 2003  
 EN 61000-3-2 : 2006  
 EN 61000-3-3 : 1995+A1 : 2001 + A2 : 2005

Affirmation	Measurements performed by	Approved by
	Title : Engineer Name : Chi, Seong-won (Signature)	Title : Manager Name : Hur, Gweon (Signature)



EMC Research Institute

2009. 07. 02



The test results in this report relate only to the following EUT, and this report shall not be reproduced except in full, without the written approval of the laboratory.

ERI-WI-ETRF001-04 Rev.No.2

**CONTENTS**

- 1. CLIENT INFORMATION**
- 2. LABORATORY INFORMATION**
- 3. EQUIPMENT UNDER TEST INFORMATION (EUT)**
- 4. TEST SPECIFICATIONS**
- 5. TEST RESULTS SUMMARY**
  - 5.1 TEST RESULTS**
  - 5.2 CONTINUOUS DISTURBANCE VOLTAGE AT MAIN TERMINALS**
  - 5.3 RADIATED DISTURBANCE : 30 MHz – 1 000 MHz**
  - 5.4 IMMUNITY TO ELECTROSTATIC DISCHARGE**
  - 5.5 IMMUNITY TO RADIATED, RADIO-FREQUENCY, ELECTROMAGNETIC FIELD.**
  - 5.6 ELECTRICAL FAST TRANSIENT/BURST IMMUNITY**
  - 5.7 SURGE IMMUNITY**
  - 5.8 IMMUNITY TO CONDUCTED DISTURBANCES, INDUCED BY RADIO-FREQUENCY FIELDS.**
  - 5.9 VOLTAGE DIPS, SHORT INTERRUPTIONS AND VOLTAGE VARIATIONS IMMUNITY.**
  - 5.10 MAINS SUPPLY VOLTAGE VARIATIONS**
  - 5.11 HARMONIC CURRENTS**
  - 5.12 VOLTAGE FLUCTUATION AND FLICKER**
- 6. PRODURCT PHOTOGRAPHS**

**1. CLIENT INFORMATION**

The EUT has been tested by request of :

Company : Samsung Electronics Co., Ltd.  
Address : 416, Maetan3-Dong, Yeongtong-Gu, Suwon-City, Gyeonggi-Do, Korea, 443-742  
Name of contact : Mr. Kang, Je-soon  
Telephone : +82-31-277-2641  
Facsimile : +82-31-277-2784

**2 LABORATORY INFORMATION**

The 10 m Semi-anechoic chamber and/or EMC facilities are used for these testing.  
These facilities were accredited by KOLAS, KCC of Korea and FCC of USA.

**Address**

EMC RESEARCH INSTITUTE.  
66-6, Jeil-Ri, Yangji-Myun, Cheoin-Gu, Yongin-Si, Gyeonggi-Do, Korea

Telephone No. : + 82-31-679-9600  
Facsimile No. : + 82-31-336-1184

**Registered No.**

KOLAS : 111  
EK : J  
MIC, FCC(DoC) : KR0030  
FCC Filing No. : 302567

**3 EQUIPMENT UNDER TEST INFORMATION(EUT)****3.1. Identification of the EUT**

Type of equipment : CCTV Camera  
Model name : SCC-C6455P

**Manufacturer Address**

Company : Tianjin Samsung Electronics Co., Ltd.  
Address : 300457 TSEC No.12, Fourth Avenue, Teda, Tianjin, China  
Country of origin : China  
Rating : AC 24 V, 1.5 A

**3.2. Additional information about the EUT**

- Class A

Basic model	Variant Model and/or type reference	Differential point
SCC-C6455P	SCC-C6453P, SCC-C7455P, SCC-C7453P	Model name

**3.3. Peripheral equipment**

Equipment needed for correct operation of the EUT is given below

Description	Model No.	Serial No.	Manufacture
Transformer	STC-24150AK	-	Planet82
Monitor	PVM-20N5U	6001634	SONY

## 4 TEST SPECIFICATIONS

### 4.1. Standards

The standards for a EUT are the following:

European Standard	IEC/CISPR Standard
EN 55022 : 2006	CISPR 22 : 2005
EN 50130-4 : 1995 + A1 : 1998 + A2 : 2003	-
EN 61000-3-2 : 2006	IEC 61000-3-2 : 2005
EN 61000-3-3 : 1995+A1 : 2001 + A2 : 2005	IEC 61000-3-3 : 1994+A1 : 2001 + A2 : 2005

## 5 TEST RESULTS SUMMARY

### 5.1 Test results

The results in this report apply only to sample tested:

Standards	Test items / Frequency	Result
EN 55022	Disturbance voltage at the mains terminals 0.15 MHz - 30 MHz	Pass
	Radiated disturbances 30 MHz - 1 000 MHz	Pass
EN 61000-4-2	Electrostatic discharge immunity	Pass
EN 61000-4-3	Radiated, radio-frequency, electromagnetic field immunity	Pass
EN 61000-4-4	Electrical fast transient/burst immunity	Pass
EN 61000-4-5	Surge immunity	Pass
EN 61000-4-6	Immunity to conducted disturbances, induced by radio-frequency fields	Pass
EN 61000-4-11	Voltage dips, short interruptions and voltage variations immunity	Pass
EN 61000-3-2	Harmonic currents	Pass
EN 61000-3-3	Voltage fluctuation and Flicker	Pass

#### 5.1.1 Measurement Uncertainty

Although the measured emissions indicate that the EUT complies with required limits, some measurements are close to these limits. When the uncertainty of measurement is considered, there is some possibility that the EUT may not be compliant

**Compliance or non-compliance with a disturbance limit shall be determined in the following manner.**

If  $U_{lab}$  is less than or equal to  $U_{cispr}$

- compliance is deemed to occur if no measured disturbance exceeds the disturbance limit;
- non-compliance is deemed to occur if any measured disturbance exceeds the disturbance limit

If  $U_{lab}$  is greater than  $U_{cispr}$

- compliance is deemed to occur if no measured disturbance, increased by  $(U_{lab}-U_{cispr})$ , exceeds the disturbance limit;
- non-compliance is deemed to occur if any measured disturbance, increased by  $(U_{lab}-U_{cispr})$ , exceeds the disturbance limit;

**5.2 CONTINUOUS DISTURBANCE VOLTAGE AT MAIN TERMINALS**  
**: Frequency range 0.15 MHz to 30 MHz**

**5.2.1 Operating Condition**

The test was carried out with continuous operation of EUT.

**5.2.2 Test set-up and test procedures**

*Photograph for Test set-up*



*Schematic for test set-up*

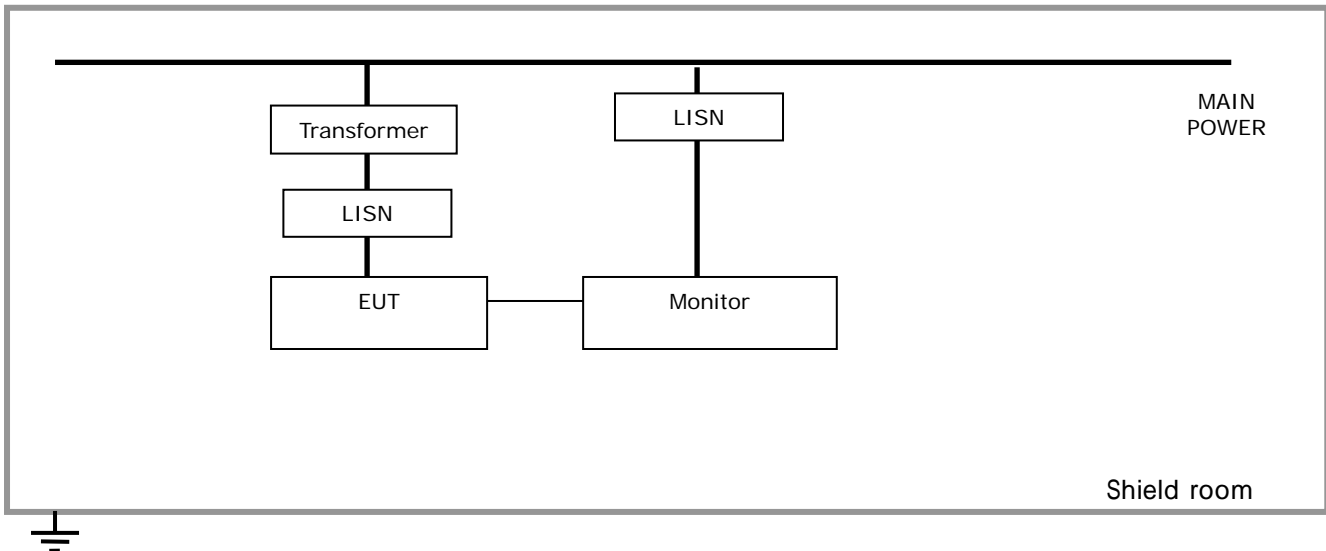

**- Procedure**

The conducted disturbance at mains terminals was measured with the equipment under Test(EUT) in a shield room. The EUT was connected to an artificial mains Network(LISN) placed on the floor. The EUT was placed on non-metallic table 0.8 m above the metallic, grounded floor. The distance to other metallic surface was at least 0.8 m. Amplitude measurements were performed with a quasi-peak detector and an average detector.

**5.2.3 Test instrument**

Instrument	Model No	Serial No.	Makers	Range (MHz)	Used
Test receiver	ESCS30	830986/015	R&S	0.009 - 2 750	O
L.I.S.N.	ESH3-Z5	100028	R&S	0.009 - 30	O
	ESH3-Z5	100030	R&S	0.009 - 30	O
Shield room	8 m(L)× 6 m(W) × 3.3 m(H)	-	-	-	O

**5.2.4 Test results**

Tested Date : 2009. 06. 26.

An overview sweep performed with peak & average detectors is included in the following data.

**Result: Pass**

**Comment:** The measured emissions level of the EUT met the requirement of specified limit.

TEST GRAPH

26 Jun 2009 18:01

Conducted Emission

EUT: CCTV CAMERA  
 Manuf:  
 Op Cond: L  
 Operator:  
 Test Spec:  
 Comment: CEC2009-0190

Scan Settings				Receiver Settings				
(2 Ranges)								
Frequencies		Step	IF BW	Detector	M-Time	Atten	Preamp	OpRge
Start	Stop							
150kHz	3MHz	3kHz	9kHz	PK+AV	1msec	Auto	ON	60dB
3MHz	30MHz	10kHz	9kHz	PK+AV	1msec	Auto	ON	60dB

Transducer	No.	Start	Stop	Name
	1	150kHz	30MHz	LISN

Final Measurement:	Detectors:	X QP / + AV
	Meas Time:	1sec
	Peaks:	8
	Acc Margin:	60 dB

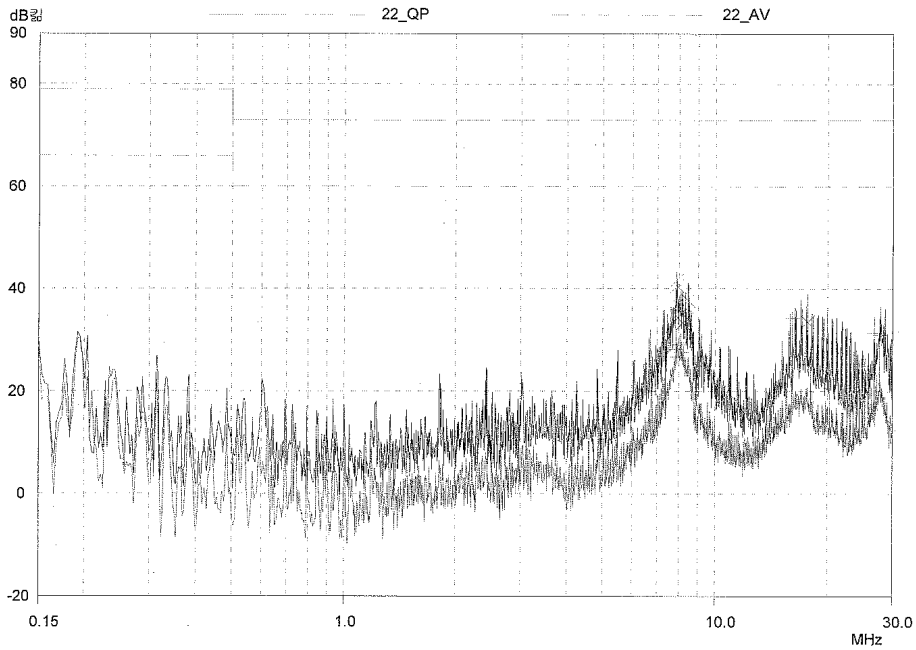

26 Jun 2009 18:01

Conducted Emission

EUT: CCTV CAMERA  
 Manuf:  
 Op Cond: L  
 Operator:  
 Test Spec:  
 Comment: CEC2009-0190

Scan Settings (2 Ranges)				Receiver Settings				
Frequencies		Step	IF BW	Detector	M-Time	Atten	Preamp	OpRge
Start	Stop							
150kHz	3MHz	3kHz	9kHz	PK+AV	1msec	Auto	ON	60dB
3MHz	30MHz	10kHz	9kHz	PK+AV	1msec	Auto	ON	60dB

Transducer	No.	Start	Stop	Name
	1	150kHz	30MHz	LISN

Final Measurement: Detectors: X QP / + AV  
 Meas Time: 1sec  
 Peaks: 8  
 Acc Margin: 60 dB

Final Measurement Results

Frequency MHz	QP Level dB <sub>μV</sub>	QP Limit dB <sub>μV</sub>	QP Delta dB
7.86	41.52	73.00	31.48
7.91	40.57	73.00	32.43
8.09	36.28	73.00	36.72
8.14	35.21	73.00	37.79
8.18999	33.31	73.00	39.69
8.32	33.94	73.00	39.06
8.46	37.70	73.00	35.30
17.64	33.51	73.00	39.49

Frequency MHz	AV Level dB <sub>μV</sub>	AV Limit dB <sub>μV</sub>	AV Delta dB
7.85	28.19	60.00	31.81
7.89	26.69	60.00	33.31
8.0	29.56	60.00	30.44
8.07	29.05	60.00	30.95
8.13	27.60	60.00	32.40
16.0	34.28	60.00	25.72
26.73	31.46	60.00	28.54
27.65	31.06	60.00	28.94

\* limit exceeded

PAGE 2

[Line : Live]

Uncertainty :  $U = -3.60 \text{ dB} \sim +3.60 \text{ dB}$  (confidence level 95 %,  $k = 2$ )

26 Jun 2009 17:55

Conducted Emission

EUT: CCTV CAMERA  
 Manuf:  
 Op Cond: N  
 Operator:  
 Test Spec:  
 Comment: CEC2009-0190

Scan Settings				(2 Ranges)				Receiver Settings			
Start	Stop	Step	IF BW	Detector	M-Time	Atten	Preamp	OpRge			
150kHz	3MHz	3kHz	9kHz	PK+AV	1msec	Auto	ON	60dB			
3MHz	30MHz	10kHz	9kHz	PK+AV	1msec	Auto	ON	60dB			

Transducer	No.	Start	Stop	Name
	1	150kHz	30MHz	LISN

Final Measurement:      Detectors: X QP / + AV  
                                  Meas Time: 1sec  
                                  Peaks: 8  
                                  Acc Margin: 60 dB

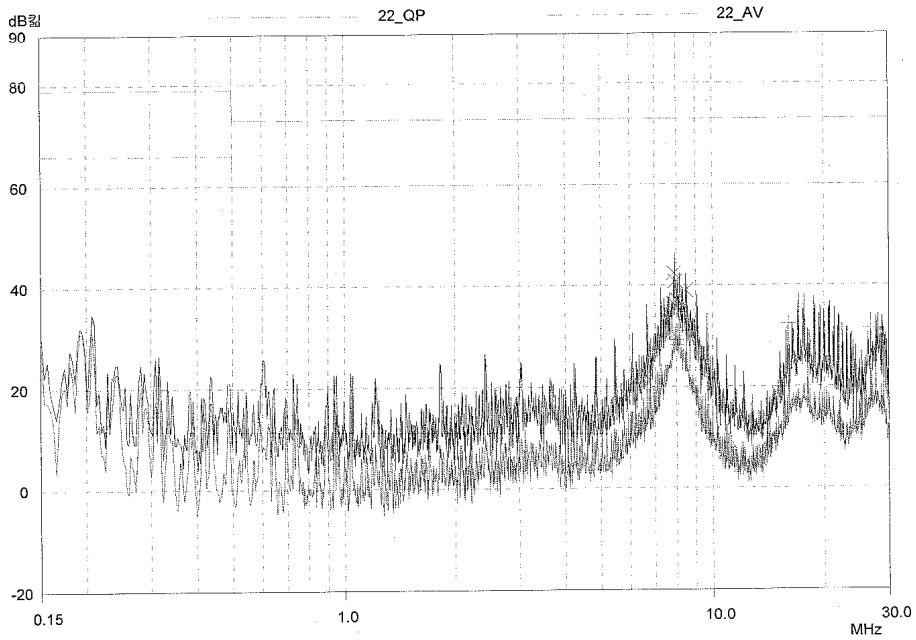

26 Jun 2009 17:55

Conducted Emission

EUT: CCTV CAMERA  
 Manuf:  
 Op Cond: N  
 Operator:  
 Test Spec:  
 Comment: CEC2009-0190

Scan Settings (2 Ranges)

Frequencies				Receiver Settings					
Start	Stop	Step	IF BW	Detector	M-Time	Atten	Preamp	OpRge	
150kHz	3MHz	3kHz	9kHz	PK+AV	1msec	Auto	ON	60dB	
3MHz	30MHz	10kHz	9kHz	PK+AV	1msec	Auto	ON	60dB	

Transducer	No.	Start	Stop	Name
	1	150kHz	30MHz	LISN

Final Measurement: Detectors: X QP / + AV  
 Meas Time: 1sec  
 Peaks: 8  
 Acc Margin: 60 dB

Final Measurement Results

Frequency MHz	QP Level dB $\mu$ V	QP Limit dB $\mu$ V	QP Delta dB
7.84	36.39	73.00	36.61
7.86	42.42	73.00	30.58
7.91	40.76	73.00	32.24
8.02999	37.03	73.00	35.97
8.05	34.97	73.00	38.03
8.09	37.00	73.00	36.00
8.13	37.90	73.00	35.10
8.46	38.98	73.00	34.02

Frequency MHz	AV Level dB $\mu$ V	AV Limit dB $\mu$ V	AV Delta dB
7.85	29.29	60.00	30.71
7.92	29.88	60.00	30.12
7.99	29.18	60.00	30.82
8.03999	28.15	60.00	31.85
8.07	30.95	60.00	29.05
8.14	31.64	60.00	28.36
16.0	32.36	60.00	27.64
26.73	31.46	60.00	28.54

\* limit exceeded

PAGE 2

[Line : Neutral]

Uncertainty :  $U = -3.60 \text{ dB} \sim +3.60 \text{ dB}$  (confidence level 95 %,  $k = 2$ )

5.3 RADIATED DISTURBANCE : 30 MHz – 1 000 MHz

5.3.1 Operating Condition

The test was carried out with continuous operation of EUT.

5.3.2 Test set-up

*Photograph for Test set-up*



*Schematic for General test set-up*

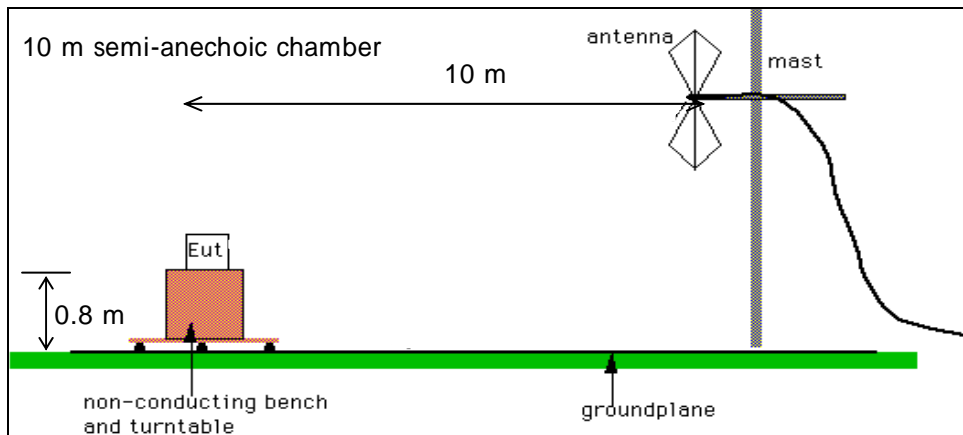

**- Test procedure**

The frequency range investigated was 30 MHz to 1 000 MHz.

All readings are quasi-peak unless stated otherwise. The half-wave dipole antenna was tuned to the frequency found during Preliminary radiated measurements. The EUT, support equipment and Interconnecting cables were re-configured to the set-up to produce the Maximum emission for the frequency and were placed on top of a 0.8 m High non-metallic 1 m X 1.5 m table. The EUT, support equipment, and interconnecting cables were re-arranged and manipulated to maximize each radiated emission.

The turntable containing the system was rotated the antenna height was varied 1 m to 4 m and stopped at the azimuth or height producing the maximum emission. And this device(EUT) was tested in 3 orthogonal planes.

The antenna measured both horizontal and vertical polarization.

**5.3.3 Test instrument**

Instrument	Model No.	Serial No.	Makers	Range (MHz)	Used
Test receiver	ESCS30	100022	R&S	0.009 – 2 750	O
L.I.S.N.	ESH3-Z5	100030	R&S	0.009 – 30	-
	ESH3-Z5	100031	R&S	0.009 – 30	-
BI LOG Antenna	VULB9156	2041	Schwarzbeck	30 – 1 500	O
Log-Periodic Antenna	UHALP9108A	0393	Schwarzbeck	300 – 2 200	-
Antenna Mast	MA240	N/A	HD	-	O
Turn Table	DT430S	N/A	HD	-	O
Spectrum	E7402A	US40240261	Agilent	0.009 – 26 000	O

**5.3.4 Test results (EN 55022)**

Tested Date : 2009. 06. 26.

Freq MHz	Reading dB(μV)	Ant pol	AF dB/m	CL dB	Result [A] dB(μV/m)	Limit [B] dB(μV/m)	Margin [A]-[B] dB
56.71	21.35	V	9.6	1.5	32.4	40	7.6
61.52	15.58	H	9.0	1.5	26.1	40	13.9
141.87	20.03	V	11.8	2.5	34.3	40	5.7
170.25	23.04	V	11.1	2.7	36.8	40	3.2
272.55	21.84	H	12.2	3.3	37.3	47	9.7
304.05	21.90	V	13.3	3.5	38.8	47	8.2
401.64	15.05	V	15.0	4.2	34.2	47	12.8

\* Meter reading: *Include Antenna Factor and cable loss*

\* Receiving Antenna Mode: *Horizontal, Vertical*

\* 10 m semi-anechoic chamber

30 MHz – 200 MHz Uncertainty :  $U = -4.26 \text{ dB} \sim +4.26 \text{ dB}$  (confidence level 95 %,  $k = 2$ )

200 MHz – 1 000 MHz Uncertainty :  $U = -3.94 \text{ dB} \sim +4.10 \text{ dB}$  (confidence level 95 %,  $k = 2$ )

**Result: Pass**

**Comment:** The measured emissions level of the EUT met the requirement of specified limit.

**5.4 IMMUNITY TO ELECTROSTATIC DISCHARGE**

**5.4.1 Operating Condition**

The test was carried out with continuous operation of EUT.

**5.4.2 Test set-up and test procedures**

*Photograph for Test set-up*



*Schematic for General test set-up*

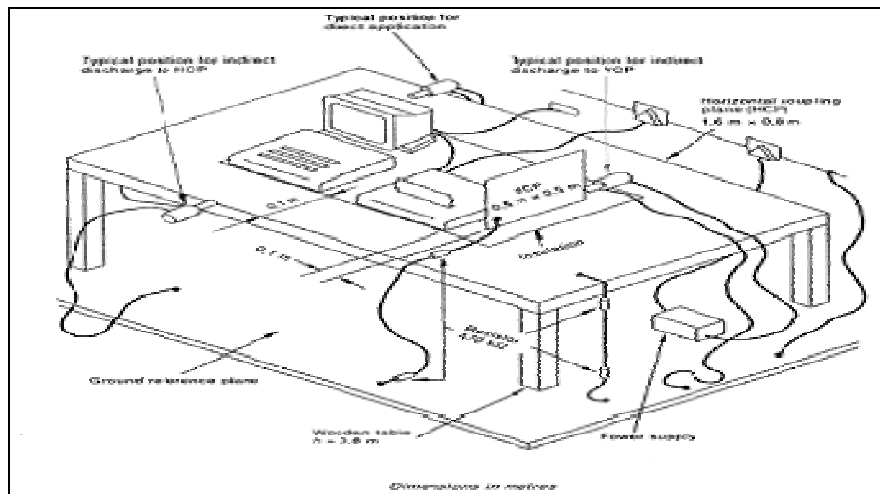

**- Test Procedures**

The EUT was placed on a non-metallic support 0.8 m above a reference ground plane (RGP).

vertical coupling plane (VCP) and horizontal coupling plane(HCP) were connected to the RGP with a cable with two 470 kΩ resistors.

**5.4.3 Test instrument**

Instrument	Model No.	Serial No.	Makers	Range (kV)	Used
ESD tester	PESD1600	H807257	Haefely	-	-
ESD tester	ESS-100LA	0100C03345	NoiseKen	0 - 31	-
ESD Generator	NSG 437	140	TESEQ AG	-	O
HCP	-	-	-	-	O
VCP	-	-	-	-	O
ERI lab	-	-	-	-	O

Reference ground plane: Immunity test area bottom

Vertical coupling plane : Aluminum 0.5 m × 0.5 m × 1.5 mm.

**5.4.4 Test mode**

1. Discharge voltage :	<input checked="" type="checkbox"/> Contact discharge : ± (2, 4, 6) kV <input checked="" type="checkbox"/> Air discharge : ± (2, 4, 8) kV
2. Discharge impedance :	<input checked="" type="checkbox"/> 330 Ω / 150 pF <input type="checkbox"/> 2 kΩ / 330 pF
3. Discharge interval :	<input checked="" type="checkbox"/> ≥ 1 s
4. Number of discharge :	<input checked="" type="checkbox"/> ≥ 10 times at each point

**5.4.5 Test protocols**

Tested Date : 2009. 06. 29.

Test point	Test level [kV]	Air/ Contact	Polarity (+ / -)	Result	Comment
Enclosure	2, 4, 8	Air	+ / -	Pass	-
Cable	2, 4, 8	Air	+ / -	Pass	-
HCP/VCP	2, 4, 6	Contact	+ / -	Pass	-

Indirect contact discharges were applied to the HCP and VCP.

Drawing of the EUT shows the location of the selected test point.

Contact discharge 

Air discharge : 

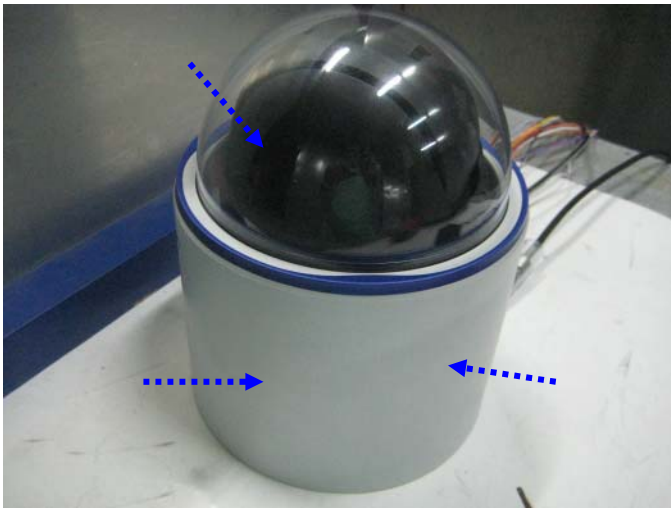

**5.4.6 Test Results**

**Result : Pass**

**Comment:** There was no damage, malfunction or change of status in this test.

## 5.5 IMMUNITY TO RADIATED, RADIO-FREQUENCY, ELECTROMAGNETIC FIELD

### 5.5.1 Operating Condition

The test was carried out with continuous operation of EUT.

### 5.5.2 Test set-up and test procedures.

The EUT was placed on a non-metallic support 0.8 m above a reference ground plane (RGP).

*Photograph for Test set-up*

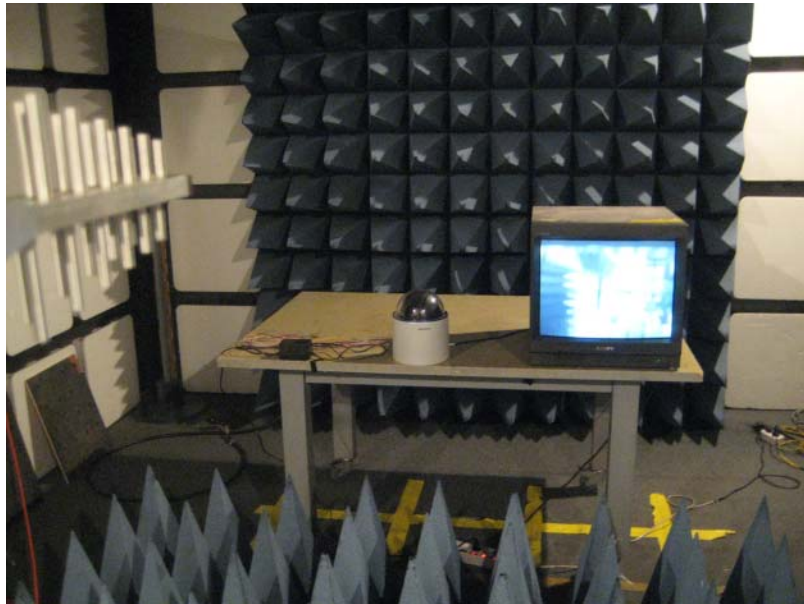

*General test set-up for radiated immunity*

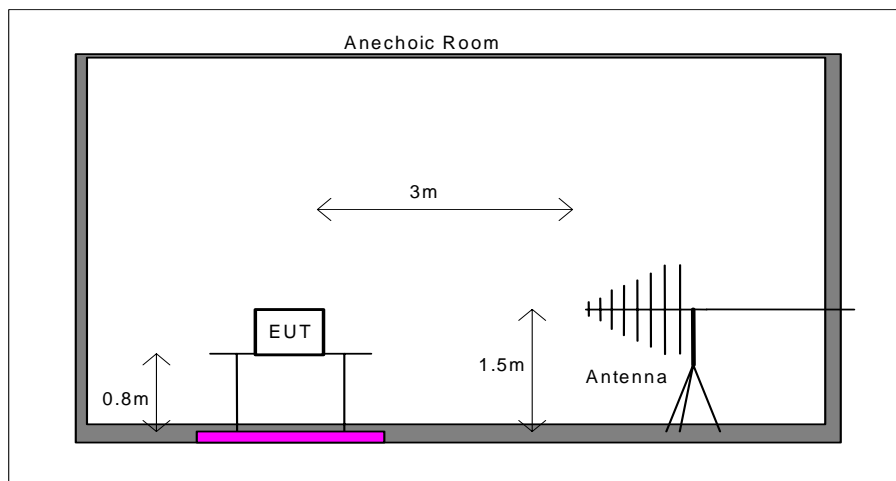



**5.5.5 Test protocols**

Tested Date : 2009. 06. 29.

Freq. [MHz]	Level [V/m]	Antenna	Positions	Result	Comment
80 - 2 000	10	H / V	Front	Pass	No deterioration
			Rear	Pass	No deterioration
			Left	Pass	No deterioration
			Right	Pass	No deterioration
	3	H / V	Front	Pass	No deterioration
			Rear	Pass	No deterioration
			Left	Pass	No deterioration
			Right	Pass	No deterioration
	1	H / V	Front	Pass	No deterioration
			Rear	Pass	No deterioration
			Left	Pass	No deterioration
			Right	Pass	No deterioration

**5.5.6 Test results**

**Result : Pass**

**Comment:** There was no observable deterioration of the picture in this test.

**5.6 ELECTRICAL FAST TRANSIENT/BURST IMMUNITY**

**5.6.1 Operating Condition**

The test was carried out with continuous operation of EUT.

**5.6.2 Test set-up and test procedures**

The EUT was placed on a non-metallic support 0.1 m above a reference ground plane(RGP).

*Photograph for Test set-up of EUT*

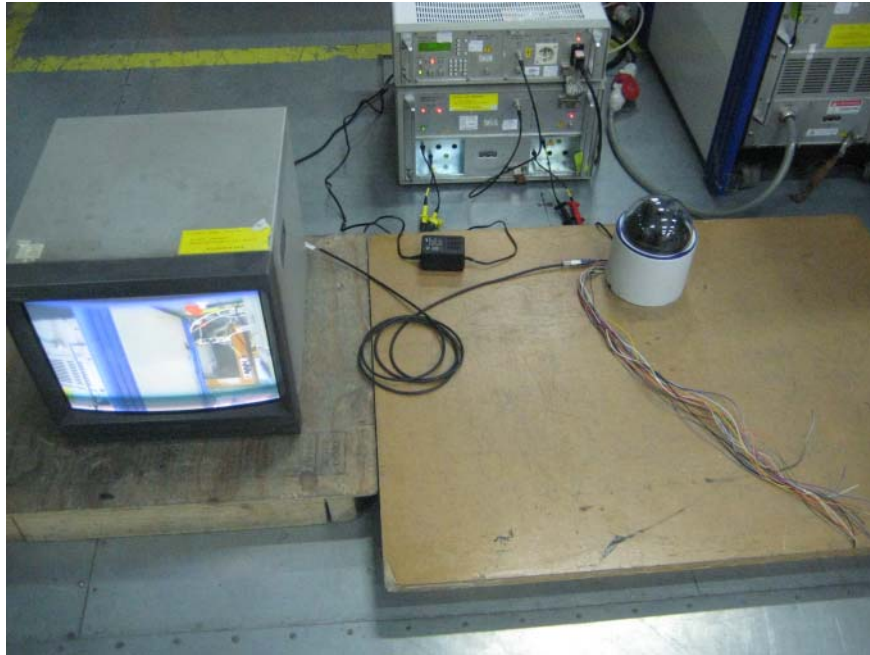

*General test set-up for immunity to EFT/B interference*

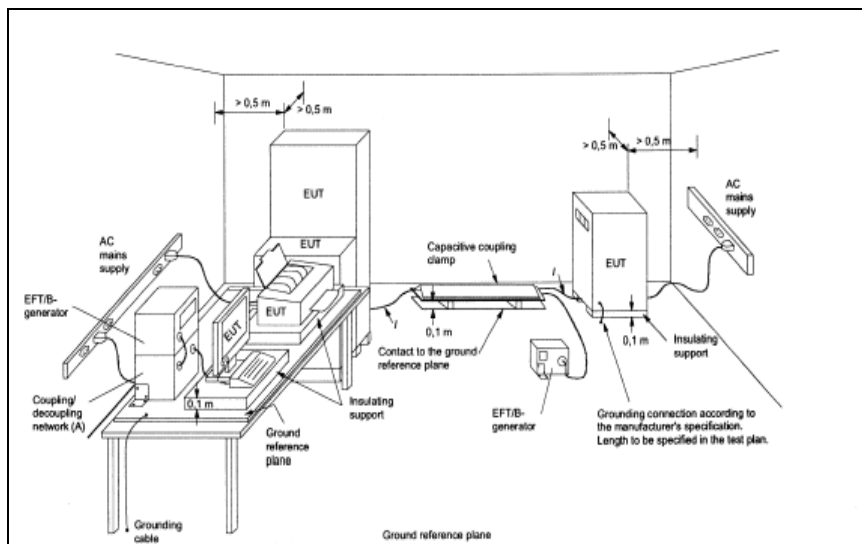

**5.6.3 Test instrument**

Instrument	Model No.	Serial No.	Makers	Range (kV)	Used
EFT tester	PEFT	081161-05	Haefely	-	O
Coupling filter	FP-EFT 32.1	081383-03	Haefely	-	-
HV- unit	PHV 42. 1	080587-02	Haefely	-	-
	PHV 41.2	083740-03	Haefely	Up to 6	O
Coupling clamp	IP4A	081555/5	Haefely	-	O
Burst Generator	EFT 500 N5.1	V0820103740	EM test	Up to 6	-
Ultra compact simulator	UCS 500 M6	0500-16	EM test	-	-
Power simulator	MV2616	0301-04	EM test	-	-
Clamp	-	-	EM test	-	-
ERI lab	-	-	-	-	O

Reference ground plane : Immunity test area bottom

**5.6.4 Test Mode**

1. Coupling mode and severity level:	<input checked="" type="checkbox"/> AC mains : $\pm (0.5, 1, 2)$ kV <input checked="" type="checkbox"/> Signal : $\pm (0.25, 0.5, 1)$ kV
2. Type of line :	<input checked="" type="checkbox"/> AC mains <input checked="" type="checkbox"/> Signal <input type="checkbox"/> Telecommunication line
3. Test mode (AC main) :	<input checked="" type="checkbox"/> L <input checked="" type="checkbox"/> N <input type="checkbox"/> PE <input checked="" type="checkbox"/> L + N <input type="checkbox"/> L + PE <input type="checkbox"/> N + PE <input type="checkbox"/> L + N + PE
4. Rise time/width :	5 kHz      5 ns / 50 ns
5. Duration :	$\geq 60$ s

**5.6.5 Test protocols**

Tested Date : 2009. 06. 30.

Test mode	Level [kV]	Polarity (+ / -)	Result	Comment
L	0.5, 1, 2	+ / -	Pass	There were white spots on the screen.
N	0.5, 1, 2	+ / -	Pass	There were white spots on the screen.
L+N	0.5, 1, 2	+ / -	Pass	There were white spots on the screen.
Signal	0.25, 0.5, 1	+ / -	Pass	There were white spots on the screen.

**5.6.6 Test results**

**Result : Pass**

**Comment:** There were white spots on the screen during this test, but it was no residual change.

## 5.7 SURGE IMMUNITY

### 5.7.1 Operating Condition

The test was carried out with continuous operation of EUT.

### 5.7.2 Test set-up and test procedures

The EUT was placed on a non-metallic support 0.8 m above a reference ground plane(RGP).

*Photograph for Test set-up of EUT*



*General test set-up for immunity to Surge interference*

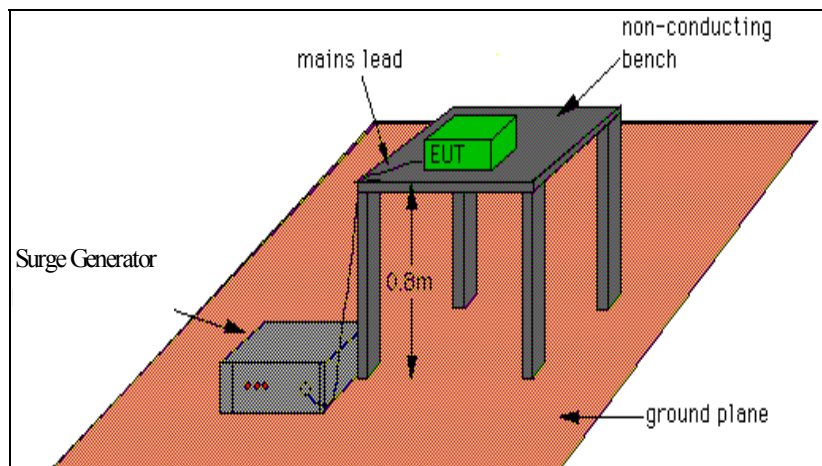

**5.7.3 Test instrument**

Instrument	Model No.	Serial No.	Makers	Range (kV)	Used
Surge tester	PSURGE6.1	081196-03	Haefely	Up to 6	O
Coupling filter	PSURGE 32.1	081839-03	Haefely	-	O
Coupling network	IP6.2	081811-10	Haefely	-	O
Decoupling network	DEC1A	081897-05	Haefely	-	O
Decoupling network	DEC3A	081583-03	Haefely	-	-
Impulse module	PHV 30.2	081299-03	Haefely	Up to 6	O
EM clamp	-	-	EM Test	-	-
Ultra compact simulator	UCS 500 M6	0500-16	EM Test	Up to 6.6	-
Power simulator	MV2616	0301-04	EM Test	-	-
ERI lab	-	-	-	-	O

Reference ground plane: Immunity test area bottom

**5.7.4 Test mode**

1. Coupling mode and severity level :	<input checked="" type="checkbox"/> AC mains Line to Line : $\pm (0.5, 1)$ kV <input checked="" type="checkbox"/> Signal line : $\pm (0.5, 1)$ kV
2. Number of transients :	5
3. Rise time/width :	<input checked="" type="checkbox"/> 1.2 $\mu$ s / 50 $\mu$ s (8 $\mu$ s / 20 $\mu$ s) <input type="checkbox"/> 1 $\mu$ s / 50 $\mu$ s (6.4 $\mu$ s / 16 $\mu$ s)
4. Test mode(AC main) :	<input checked="" type="checkbox"/> L + N <input type="checkbox"/> L + PE <input type="checkbox"/> N + PE
5. Phase angles :	0° - 360° / 90° Step
6. Repetition rate :	60 s

**5.7.5 Test protocols**

Tested Date : 2009. 07. 01.

Test mode	Level [kV]	Phase[°]	Diff. / Com	Result	Comment
L - N	0.5, 1	0° - 360° per 90°	Diff	Pass	No deterioration
Signal	0.5, 1	-	Com	Pass	No deterioration

**5.7.6 Test results**

**Result : Pass**

**Comment:** There was no damage, malfunction or change of status in this test.

**5.8 IMMUNITY TO CONDUCTED DISTURBANCES, INDUCED BY RADIO-FREQUENCY FIELDS**

**5.8.1 Operating Condition**

The test was carried out with continuous operation of EUT.

**5.8.2 Test set-up and test procedures**

*Photograph for Test set-up of EUT*



*General test set-up for immunity to conducted disturbances*

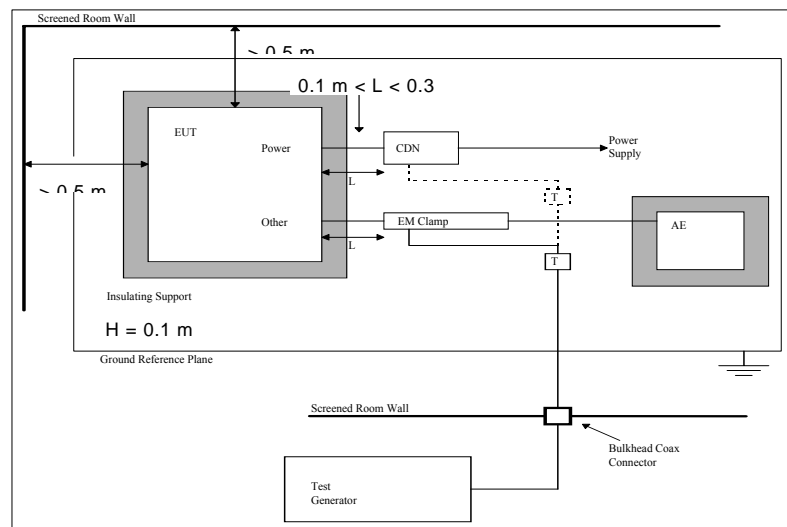

- **Test procedure**

The EUT was placed on a non-metallic support 0.1 m above a reference ground plane(RGP) with the coupling/decoupling networks (CDN) placed 0.3 m from the EUT on the RGP.

The disturbance signal level was calibrated as specified in the standard. A power meter for calibration was connected to the EUT side of the CDN through a 150 Ω - 50 Ω adapter. The auxiliary equipment (AE) side of the network was terminated with 150 Ω to ground during the calibration. The generator settings obtained during the calibration procedure were later repeated in the tests.

**5.8.3 Test instrument**

Instrument	Model No.	Maker	Serial No.	Range (MHz)	Used
Signal generator	SMT03	R&S	831809/008	0.005 - 3 000	-
Power meter	NRVD	R&S	832025/049	-	-
Power amplifier	500A100AM3	AR	26379	0.01 - 100	-
Two channel Unit	OAM-01B	Teseo	22154	-	-
Continuous Wave Simulator	CSW 500 C S1	EM TEST	V0711102310	0.1 - 300	O
CDN	FCC-801-M2	FCC	9969	0.15 - 230	O
	FCC-801-M3-50A	FCC	06068	0.15 - 230	-
	FCC-801-M4	FCC	2008	-	-
	FCC-801-M5	FCC	2010	-	-
EM clamp	F-203I-32MM	FCC	506	-	O
ERI lab	-	-	-	-	O

Reference ground plane: Immunity test area bottom

**5.8.4 Test Mode**

1. Frequency range :	<input checked="" type="checkbox"/> 150 kHz – 100 MHz <input type="checkbox"/> 150 kHz – 230 MHz <input type="checkbox"/> 150 kHz – 500 MHz
2. Test level :	<input checked="" type="checkbox"/> 120 dB $\mu$ V(1 V) <input checked="" type="checkbox"/> 130 dB $\mu$ V(3 V) <input checked="" type="checkbox"/> 140 dB $\mu$ V(10 V)
3. Modulation :	<input checked="" type="checkbox"/> AM : 1 kHz, 80 % <input checked="" type="checkbox"/> PM : 1 Hz (0.5 s ON : 0.5 s OFF)
4. Frequency Step :	<input checked="" type="checkbox"/> log 1 % step <input type="checkbox"/> log 3 % step <input type="checkbox"/> log 5 % step
5. Dwell time :	<input checked="" type="checkbox"/> 3 s <input type="checkbox"/> 2 s <input type="checkbox"/> 1 s
6. Lines for test :	<input checked="" type="checkbox"/> AC power Port : M2 <input checked="" type="checkbox"/> Signal : EM clamp <input type="checkbox"/> Telecommunication line

**5.8.5 Test protocols**

Tested Date : 2009. 06. 30.

Freq. [MHz]	Level [dB $\mu$ V]	Tested line	Result	Comment
0.15 - 100	140 dB $\mu$ V	AC Main	Pass	Horizontal screen noise occurred.
	130 dB $\mu$ V	AC Main	Pass	No deterioration
	120 dB $\mu$ V	AC Main	Pass	No deterioration
0.15 - 100	140 dB $\mu$ V	Signal	Pass	Horizontal screen noise occurred.
	130 dB $\mu$ V	Signal	Pass	Horizontal screen noise occurred.
	120 dB $\mu$ V	Signal	Pass	No deterioration

**5.8.6 Test results**

**Result : Pass**

**Comment:** There was no permanent damage or change to the EUT at U<sub>0</sub>=140 dB $\mu$ V.

At U<sub>0</sub>=130 dB $\mu$ V, there was screen noise but after test, the EUT can still be used.

There was no observable deterioration of the picture at U<sub>0</sub>=120 dB $\mu$ V.

## 5.9 VOLTAGE DIPS, SHORT INTERRUPTIONS AND VOLTAGE VARIATIONS IMMUNITY

### 5.9.1 Operating Condition

The test was carried out with continuous operation of EUT.

### 5.9.2 Test set-up and test procedures

The shortest mains cable is used, unless otherwise specified by the manufacturer.

*Photograph for Test set-up of EUT*



*General test set-up for immunity to voltage dips, short interruptions*

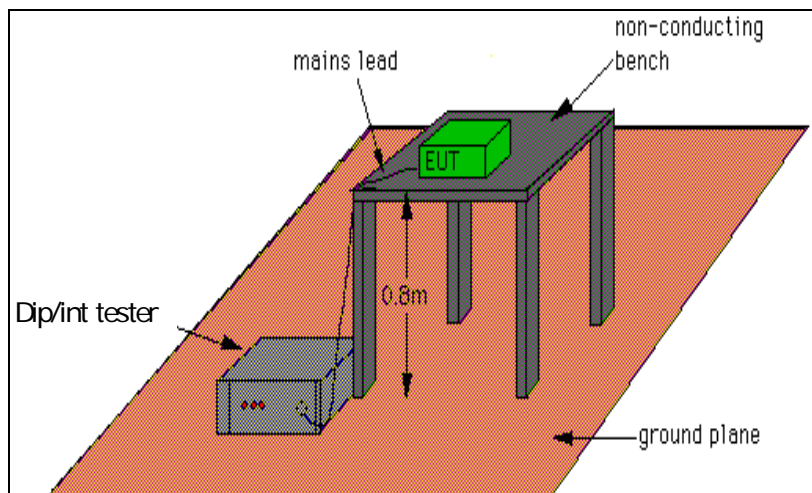

**5.9.3 Test instrument**

Instrument	Model No.	Serial No.	Makers	Range-	Used
Line interference test system	PLINE 1610	0814510-02	Haefely	-	-
Power simulator	MV2616	0301-04	EM test	-	O
Ultra compact generator	UCS 500 M6	0500-16	EM test	-	O

Reference ground: Shield room bottom

**5.9.4 Test Mode**

Tested Date: 2009. 07. 01.

Voltage reduction %UT	Duration /Period	Phase (°)	Count number	Result	Comment
30 %	0.5	0, 180	3 T	Pass	No deterioration
	1	0	3 T	Pass	No deterioration
	5	0	3 T	Pass	No deterioration
	10	0	3 T	Pass	No deterioration
60 %	0.5	0, 180	3 T	Pass	No deterioration
	1	0	3 T	Pass	No deterioration
	5	0	3 T	Pass	No deterioration
	10	0	3 T	Pass	No deterioration
100 %	0.5	0, 180	3 T	Pass	No deterioration
	1	0	3 T	Pass	No deterioration
	5	0	3 T	Pass	No deterioration

**5.9.5 Test results**

**Result : Pass**

**Comment:** There was no damage, malfunction or change of status in this test.

**5.10 MAINS SUPPLY VOLTAGE VARIATIONS**

**5.10.1 Operating Condition**

The test was carried out with continuous operation of EUT.

**5.10.2 Test set-up and test procedures**

The shortest mains cable is used, unless otherwise specified by the manufacturer.

*Photograph for Test set-up of EUT*



**5.10.3 Test instrument**

Instrument	Model No.	Serial No.	Makers	Range	Used
Line interference test system	PLINE 1610	0814510-02	Haefely	-	-
Power simulator	MV2616	0301-04	EM test	-	-
Ultra compact generator	UCS 500 M6	0500-16	EM test	-	-
Power Simulation System	EMVD 90000/PAS	A4230	SPITZENBERGER+SPIES GMBH&CO.KG	-	O

Reference ground: Shield room bottom

**5.10.4 Operating mode**

Tested Date : 2009. 06. 26.

Supply voltage Max %UT	Unom(V)	Supply voltage	Result	Comment
Umax	26.4	Unom + 10 %	A	No deterioration
Umin	20.4	Umin – 15 %	A	No deterioration

**5.10.5 Test results****Result : Pass****Comment:** There was no damage, malfunction or change of status in this test.

5.11 HARMONIC CURRENTS

5.11.1 Operating Condition

The test was carried out with continuous operation of EUT.

5.11.2 Test set-up and test procedures

Emission tests shall be conducted with the user’s operation controls or automatic programs set to the mode expected to produce the maximum total harmonic current(THC) under normal operating conditions. This defines the equipment set-up during emission tests and not a requirement to measure THC or to conduct searches for worst-case emissions

The equipment is tested as presented by, and in accordance with information provided by, the manufacturer.

Measurement Circuit for EUT( only single phase)

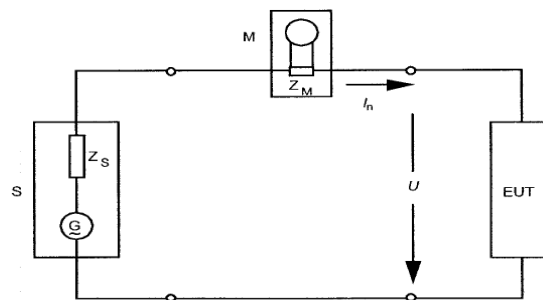

IEC 1778/2000

- |     |                       |                |   |
|-----|-----------------------|----------------|---|
| S   | power supply source   | Z <sub>M</sub> | input impedance of measurement equipment          |
| M   | measurement equipment | Z <sub>S</sub> | internal impedance of the supply source           |
| EUT | equipment under test  | I <sub>n</sub> | harmonic component of order n of the line current |
| U   | test voltage          | G              | open-loop voltage of the supply source            |



Photograph of Test set-up

5.11.3 Test instrument

Instrument	Model No.	Serial No.	Makers	Used
Power Simulation System	EMVD 90000/PAS	A4230	Spitzenberger+ Spies GmbH&Co.KG	O

Reference ground: Shield room bottom

5.11.4 Test result

Tested Date : 2009. 06. 26.

Name: Serial no:  
Department: Operating modes: CEC2009-0190  
Company: Comment1: --  
Test report no: Comment2: --  
Device: CCTV CAMERA Comment3: --  
Specimen: Comment4: --  
Manufacturer: SAMSUNG Date: 26.06.2009  
Type: Test date: 26.06.2009

Maximum rms current and corresponding value in the window 500:  
Voltage: 230.61 Vrms THD=0.01 % THV=0.013 V POHV=0.003 VPWHD=0.01 %  
Current: 0.164 Arms THD=51.77 % THC=0.076 A POHC=0.001 APWHD=7.02 %  
Power: 13.8 W P1=13.8 W 37.8 VA  
Powerfactor: 0.364 CosPhi1: 0.411

Testconditions EN 61000-3-2:2008, f=50 Hz, Phase=L1, Range=0.80 A, No Ztest selected  
Time window cycles=10/12 (200ms), Grouping of harmonics=on

HARMONIC ANALYSIS: Test PASS  
Tobs = entire measurement; POHC: avg=0.00 A, limits=0.25 A

Ha	Entire measurement (2.5 min = 750 time windows)			Worst 2.5 min		Average		P A S S	F I L E
	MaximumWindow	EN61000-3-2 Class A	Margin	100 to 150 to Ex-	100 to Ex-	Value	Ex-ceeded		
DC	0.0007 A	419	-----	0	0	0	n.e.	0.0005 A	0 X
1	0.1454 A	598	-----	0	0	0	n.e.	0.1385 A	0 X
2	0.0009 A	120	1.0800 A -89.9 %	0	0	0	n.e.	0.0008 A	0 X
3	0.0590 A	691	2.3000 A -97.4 %	0	0	0	n.e.	0.0560 A	0 X
4	0.0004 A	667	0.4300 A -99.9 %	0	0	0	n.e.	0.0004 A	0 X
5	0.0479 A	597	1.1400 A -95.8 %	0	0	0	n.e.	0.0455 A	0 X
6	0.0001 A	125	0.3000 A -100.0 %	0	0	0	n.e.	0.0001 A	0 X
7	0.0041 A	750	0.7700 A -99.5 %	0	0	0	n.e.	0.0039 A	0 X
8	0.0001 A	581	0.2300 A -100.0 %	0	0	0	n.e.	0.0000 A	0 X
9	0.0068 A	68	0.4000 A -98.3 %	0	0	0	n.e.	0.0062 A	0 X
10	0.0000 A	184	0.1840 A -100.0 %	0	0	0	n.e.	0.0000 A	0 X
11	0.0029 A	597	0.3300 A -99.1 %	0	0	0	n.e.	0.0026 A	0 X
12	0.0001 A	352	0.1533 A -100.0 %	0	0	0	n.e.	0.0000 A	0 X
13	0.0030 A	255	0.2100 A -98.5 %	0	0	0	n.e.	0.0028 A	0 X
14	0.0000 A	350	0.1314 A -100.0 %	0	0	0	n.e.	0.0000 A	0 X
15	0.0014 A	596	0.1500 A -99.0 %	0	0	0	n.e.	0.0014 A	0 X
16	0.0000 A	445	0.1150 A -100.0 %	0	0	0	n.e.	0.0000 A	0 X
17	0.0008 A	597	0.1324 A -99.4 %	0	0	0	n.e.	0.0007 A	0 X
18	0.0000 A	407	0.1022 A -100.0 %	0	0	0	n.e.	0.0000 A	0 X
19	0.0011 A	68	0.1184 A -99.1 %	0	0	0	n.e.	0.0000 A	0 X
20	0.0000 A	626	0.0920 A -100.0 %	0	0	0	n.e.	0.0000 A	0 X
21	0.0004 A	130	0.1071 A -99.6 %	0	0	0	n.e.	0.0004 A	0 X
22	0.0000 A	278	0.0836 A -100.0 %	0	0	0	n.e.	0.0000 A	0 X
23	0.0007 A	36	0.0978 A -99.3 %	0	0	0	n.e.	0.0000 A	0 X
24	0.0000 A	39	0.0787 A -100.0 %	0	0	0	n.e.	0.0000 A	0 X
25	0.0006 A	188	0.0900 A -99.4 %	0	0	0	n.e.	0.0005 A	0 X
26	0.0000 A	408	0.0708 A -100.0 %	0	0	0	n.e.	0.0000 A	0 X
27	0.0003 A	68	0.0833 A -99.6 %	0	0	0	n.e.	0.0003 A	0 X
28	0.0002 A	299	0.0657 A -100.0 %	0	0	0	n.e.	0.0000 A	0 X
29	0.0004 A	597	0.0776 A -99.5 %	0	0	0	n.e.	0.0004 A	0 X
30	0.0000 A	511	0.0613 A -100.0 %	0	0	0	n.e.	0.0000 A	0 X
31	0.0003 A	131	0.0726 A -99.5 %	0	0	0	n.e.	0.0000 A	0 X
32	0.0000 A	698	0.0575 A -100.0 %	0	0	0	n.e.	0.0000 A	0 X
33	0.0002 A	595	0.0682 A -99.6 %	0	0	0	n.e.	0.0002 A	0 X
34	0.0000 A	54	0.0541 A -100.0 %	0	0	0	n.e.	0.0000 A	0 X
35	0.0003 A	597	0.0643 A -99.6 %	0	0	0	n.e.	0.0003 A	0 X
36	0.0000 A	316	0.0511 A -100.0 %	0	0	0	n.e.	0.0000 A	0 X
37	0.0002 A	629	0.0608 A -99.6 %	0	0	0	n.e.	0.0002 A	0 X
38	0.0000 A	248	0.0484 A -100.0 %	0	0	0	n.e.	0.0000 A	0 X
39	0.0002 A	594	0.0577 A -99.7 %	0	0	0	n.e.	0.0002 A	0 X
40	0.0000 A	612	0.0460 A -100.0 %	0	0	0	n.e.	0.0000 A	0 X

Result: Pass

Comment: The measured emissions level of the EUT met the requirement of specified limit.

**5.12 VOLTAGE FLUCTUATION AND FLICKER**

**5.12.1 Operating Condition**

The test was carried out with continuous operation of EUT.

**5.12.2 Test set-up photo**

Unless the test conditions for the measurement of voltage fluctuations and flicker are given. A controls or automatic program shall be set to produce the most unfavorable sequence of voltages, using only those combinations of controls and programs which are mentioned by the manufacturer in the instruction manual

*Photograph of Test set-up*



**5.12.3 Test instrument**

Instrument	Model No.	Serial No.	Makers	Used
Flicker Test System	ARS 16/3	A326007/01203	Spitzenberger+Spies GmbH&Co.KG	-
Power Simulation System	EMVD 90000/PAS	A4230	Spitzenberger+Spies GmbH&Co.KG	O

Reference ground: Shield room bottom

5.12.4 Test result

Tested Date : 2009. 06. 26.

Name:		Serial no:	
Department:		Operating modes:	
Company:		Comment1:	CEC2009-0190
Test report no:		Comment2:	--
Device:	CCTV CAMERA	Comment3:	--
Specimen:		Comment4:	--
Manufacturer:	SAMSUNG	Date:	26.06.2009
Type:		Test date:	26.06.2009

Testconditions: EN 61000-3-3:1995+A1+A2 / 230 V / 50 Hz / Phase L1 / Obs 1 x 1C

FLICKER: Test PASS!

Time	Pmax	Pst	Sliding PIt(t)>3.30%	s[dmax [%]	dc [%]	PASS/FAIL
11:05:55	0.038	0.1390	-----	0.000	0.058	----- X
Limits:		1.000	0.650	0.500	4.000	3.300
PIt: 0.139000						
Evaluated: PST, dc, dmax, d(t)						

FLICKER: Source test PASS!

Time	Pmax	Pst	Sliding PIt(t)>3.30%	s[dmax [%]	dc [%]	PASS/FAIL
11:05:55	0.034	0.1310	-----	0.000	0.057	----- X
PIt: 0.131000						
Evaluated: PST <= 0.4 dmax < 20% dmax1						

Tested with EMC test software VZ 415 / PAS8000 by Spitzenreiter \* ipac GmbH & Co. KG, Schmalz 30-34, D-384294 Verden, 26.06.2009

**Result: Pass**

**Comment:** The measured emissions level of the EUT have found the below of the specified limit.

## 6 PRODUCT PHOTOGRAPHS

### 6.1. Photograph of EUT

